

FTI OPERATIONS, MAINTENANCE, AND REPAIR MANUAL

Medium Brute Puller Unit

**Part #2720-007, Log #1204
Revision C**

November 18, 2011



Fatigue Technology (FTI) is a world-leading aerospace engineering and manufacturing company. FTI pioneered cold expansion technology (which provides solutions to fatigue problems associated with holes in metal structures) back in 1969 and have advanced this science to develop innovative bushing and fastener products. These proprietary products and associated tooling may be covered by patents or agreements owned by, or exclusively licensed to Fatigue Technology. Use of tooling procured from other than a licensed source may constitute patent infringement.

The detailed tooling information in this manual was compiled and written by FTI. The tooling was designed specifically for use with FTI's Cold Expansion (Cx™) Systems. FTI cannot be held responsible for damage or injury as a result of operating this equipment if it is used for other than the process intended, with any other tooling not provided by FTI, or not used in accordance with the instructions contained in this manual. To avoid personal injury, please observe all safety precautions and instructions. FTI reserves the right to change specifications or configurations of equipment detailed in this manual as part of our ongoing technical and product improvement programs. If you have any questions about the use or serviceability of this equipment, please contact our Technical Sales Department.

FTI's systems and processes are the subject matter of one or more of the following patents: 4,809,420, 4,885,829, 4,934,170, 5,083,363, 5,096,349, 5,103,548, 5,127,254, 5,129,253, 5,218,854, 5,245,743, 5,305,627, 5,341,559, 5,380,136, 5,405,228, 5,433,100, 5,468,104, 6,077,010, 6,183,180, 6,487,767, 6,792,657, 6,990,722, 7,024,908, 7,100,264; 1,061,276, 513,898, 692015124, 581,385, 69310828, 468,598, 69105390, 643,231, 69414946, 696,686, 785,366, 1032769, and other patents pending. These systems and processes are tooling critical and must be performed in accordance with FTI's specifications or controlling documents. To ensure proper results from FTI's cold expansion systems and to be licensed to use FTI's patented processes, it is essential that FTI's complete integrated system of tooling be purchased and utilized. The use of tooling purchased from other than a licensed supplier could jeopardize fatigue life enhancement and may constitute patent infringement.

FTI reserves the right to change the specifications or configurations of tooling detailed in this manual as part of its ongoing technical and product information program. Should inconsistencies occur between your tooling and this manual, please contact our Technical Sales Department.

ABOUT FATIGUE TECHNOLOGY

Fatigue Technology (FTI) has provided innovative solutions to fatigue problems in metal structures since 1969. Complete systems of tooling are used worldwide to enhance the fatigue life of holes in airframes, turbine engines, and other critical structures.

The FTI staff of professionals provides a full range of support services including:

- Application engineering
- Detailed project planning, implementation and management
- On-site assistance, including training and tool room setup
- Complete inventory allowing FTI to respond quickly to customer' requirements

The Sales Department is always available to assist with special fatigue enhancement requirements. Please contact FTI with questions at any time.

TABLE OF CONTENTS

SECTION	DESCRIPTION	PAGE
1.0	Introduction.....	1
1.1	About the Medium Brute Puller Unit.....	1
1.2	General Specifications.....	1
1.3	General Description.....	2
2.0	Safety.....	5
3.0	Puller Unit Operating Instructions.....	7
3.1	Puller Unit Setup Procedure.....	7
3.2	Actuation of the Puller.....	7
4.0	Maintenance.....	9
4.1	General Cleaning.....	9
4.2	Lubrication.....	9
4.3	Inspection.....	9
4.4	Assembly and Disassembly.....	9
5.0	Troubleshooting.....	11
5.1	PowerPak Will Not Build Full Hydraulic Pressure.....	11
5.2	Puller Retracts on First Trigger Actuation, But Will Not Return to Start Position.....	12
5.3	PowerPak Will Not Generate Constant Pressure (Hiccups).....	13
5.4	PowerPak Will Not Operate or Maintain Sufficient Pressure (6,000 psi).....	14
5.5	Mandrel Sticks in Hole When Puller Activated.....	15
6.0	Illustrated Parts Breakdown.....	17
6.1	Medium Brute Rework Kit (MB-CT-RK).....	17
6.2	Medium Brute Seal Kit (MB-SK).....	18
6.3	Previous Trigger Assembly.....	19
6.4	Medium Brute Parts List; Assembly Diagram.....	20

TABLE OF CONTENTS (Continued)

SECTION	DESCRIPTION	PAGE
FIGURES		
Figure 1.3-1	Medium Brute Puller Unit Parts	2
Figure 1.3-2	Medium Brute Puller Unit Specifications.....	3
Figure 2.0-1	Location of Air Disconnect.....	5
Figure 2.0-2	Safety Stickers	6
Figure 5.1-1	FT-20 PowerPak	11
Figure 5.1-2	FT-200 PowerPak	11
Figure 5.2-1	Hydraulic Quick Coupler.....	12
Figure 5.2-2	Hydraulic Quick Coupler (FT-200) Location	12
Figure 5.3-1	Trigger Response Valve (FT-200) Location	13
Figure 5.3-2	Trigger Response Valve (FT-20) Location	13
Figure 5.3-3	Hydraulic Quick Coupler (FT-20) Location	13
Figure 5.4-1	Pressure Gage (FT-200) Location.....	14
Figure 6.1-1	Diagram of Cartridge Trigger Assembly	17
Figure 6.2-1	Medium Brute Seal Kit	18
Figure 6.3-1	Diagram of Previous Trigger Assembly	19
Figure 6.4-1	Medium Brute Assembly Diagram	21
TABLES		
Table 1.3-1	Medium Brute Specifications	3
Table 6.1-1	Medium Brute Rework Kit (MB-CT-RK)	17
Table 6.2-1	Medium Brute Seal Kit (MB-SK).....	18
Table 6.3-1	Parts List for Previous Trigger Assembly.....	19
Table 6.4-1	Medium Brute Parts List.....	20

SECTION 1.0: INTRODUCTION

This instruction manual contains information on the operation and maintenance of the Medium Brute Puller Unit (MBPU). To obtain optimum performance and many years of trouble-free service, operate the puller unit properly and carefully follow maintenance procedures. **Read this manual before operating the puller unit**, and retain the manual for future reference. If requested, FTI will provide this manual in the language of the end-user.

1.1 ABOUT THE MEDIUM BRUTE PULLER UNIT

The Medium Brute hydraulic puller unit is a powerful, moderately sized, lightweight tool specifically designed for use with FTI's patented Split Sleeve Cold Expansion process. The MBPU is designed to pull a mandrel through a hole with the pre-lubricated stainless steel split sleeves used in this process.

The MB pullers have a maximum pull force of 24,000 pounds ($1.1 \times 10^5 \text{N}$) at 10,000 psi (689.5 bar) pump pressure. The MB is available in sizes (models) capable of cold expanding holes up to 1 inch (25.4 mm) in diameter and 7 inches (177.8 mm) deep in aluminum, and up to 7/8 inch (22.2 mm) diameter in steel and titanium. The Medium Brute is available in various models to accommodate multiple material stackups, including "-V" models with high-visibility hose markings.

The Medium Brute has a fail-safe air control system that causes the puller retraction cycle to be interrupted whenever the operator releases finger pressure on the trigger or in the event of air or hydraulic hose failure. All puller units operate in conjunction with either of FTI's PowerPak air-hydraulic power units, the standard FT-200 or portable FT-20 (and are compatible with older units IW100MF and IW10MF). The MB has proven to be very reliable, and requires minimal maintenance.

1.2 GENERAL SPECIFICATIONS

Hydraulic Fluid Requirements	U.S. MIL-Spec #5606
Air Line Requirements.....	3/8 to 1/2 inch (9.5 to 12.7 mm) ID
Air Flow Requirements (via PowerPak)	45 cfm (1274.3 liter/minute)
Stackup Capacity (Grip)	Material up to 7 inches (177.8 mm)
Actuation	Pneumatic
Operation.....	Hydraulic
Compatible PowerPaks	FT-200 or FT-20
Fail-safe	Air logic safety circuit halts mandrel retraction when trigger is released
Replacement Seal Kit.....	Medium Brute Seal Kit (MB-SK)
Weight (without tooling)*	
MB-30.....	20 pounds
MB-70.....	24 pounds
BMB-10	19 pounds
Emission sound pressure level at the work station (according to EN ISO 11201:1995) on load	83.1 dB(A)
Weighted hand-arm vibration at the handle (according to EN 28662-1:1993) on load	<2.5 m.S ²

*A user-supplied suspension system might be required at the end use site. The requirement for a suspension system is based on the end user's workplace lifting and weight standards. A risk analysis for the suspension is necessary to maintain compliance to end user's standards or directives. All risks involved with the suspension of the Big Brute are the responsibility of the end user. User instructions and training regarding the suspension system are the responsibility of the end user.

1.3 GENERAL DESCRIPTION

- Air actuated, hydraulic puller is capable of cold expanding up to 15/16-inch (23.8 mm) diameter in aluminum and mild steel, and up to 3/4-inch (19.1 mm) diameter in titanium and high-strength steel.
- Maximum pull force is 24,000 pounds (1.1×10^5 Newtons) at 10,000 psi (389.5 bar) of hydraulic pressure.
- Includes a 10-foot (3.0 mm) hose assembly, spanner wrench, nose cap pin wrench, and alternate 7/8-inch (22.2 mm) threaded adapter for larger mandrel sizes.
- Available in 16.7 to 24.0 inch (0.4 to 0.6 meter) overall lengths depending on the model.
- Up to 7.0 inches (177.8 mm) material stackup capacity.
- Hydraulic pressure provided by the FT-200 or FT-20 PowerPak.



Figure 1.3-1
Medium Brute Puller Unit Parts

**Table 1.3-1
Medium Brute Specifications**

Model Number	Maximum Material Stackup	L (Reference Section 2.2*)	F (Reference Section 2.2*)	Weight	Stroke
MB-30	3.3 inches 83.8 mm	18.2 inches 462.3 mm	8.6 inches 218.4 mm	20 lbs 9.1 kg	5.2 inches 132.1 mm
MB-70	7.0 inches 177.8 mm	25.5 inches 647.7 mm	11.6 inches 294.6 mm	24 lbs 10.9 kg	8.9 inches 226.1 mm
BMB-10	1.0 inch 25.4 mm	15.7 inches 398.8 mm	7.1 inches 180.3 mm	19.2 lb 8.71 kg	3.16 inches 80.3 mm

*Refers to the FTI Tooling Catalog, current revision.

Nosecap Selection: The Medium Brute Puller Unit is compatible with both the standard nose caps (Section 2*) or the extension nose caps (Section 2*).

Mandrel Selection: The Medium Brute Puller Unit is directly compatible with standard Type 2 or Type 5 threaded mandrels (Section 2*).

* Refers to the FTI Tooling Catalog, current revision.

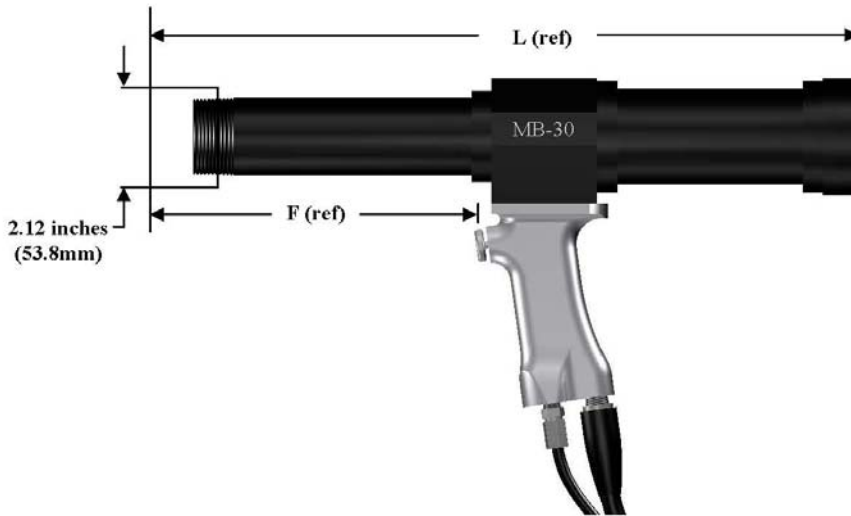

**Figure 1.3-2
Medium Brute Puller Unit Specifications**

This page is intentionally left blank for two-sided printing.

SECTION 2.0: SAFETY

Consult PowerPak manual for safety precautions before connecting the puller unit.

When used in accordance with these instructions, the puller unit is safe and easy to use. All general safety precautions associated with hydraulic and pneumatically operated power tools should be observed. Many of these are noted in this section. Ultimately, the operator is responsible for personal safety; however, the following general safety precautions should be observed.

CAUTION: The weight of this unit may require a suspension system per the end-user's workplace lifting standards.

1. Wear eye and ear protection when operating the puller unit.

2. Disconnect the air supply when:
- Maintenance is to be performed.
- Hydraulic hose is disconnected.
- PowerPak is not in use.

3. In the event of a ruptured or leaking hydraulic hose, **IMMEDIATELY RELEASE THE TRIGGER AND DISCONNECT THE AIR LINE**, at the air coupler, from the PowerPak (see Figure 2.0-1). **Never use your hands** to grasp a leaking hose under pressure. The force of escaping hydraulic fluid could cause serious injury. If hydraulic oil should penetrate the skin, medical attention must be sought immediately.

4. Keep hands away from nosecap assembly while holding nosecap against the workpiece.

5. Release puller unit trigger when mandrel clears the workpiece, or becomes stuck.

6. End cap must always be in place while in use. Injury may occur if end cap is removed during operation. All new puller units have been modified to ensure operator safety. However, rework instructions are available from FTI for any Medium Brute Puller Units that don't have a role pin and air seal adapter like that shown in Figure 6.3-1.

7. Before operating the pump, tighten all hose connections using the proper tools. Do not overtighten the connections. Connections need only be tightened securely and leak-free. Overtightening may cause premature thread failure or high-pressure fittings to split at pressures lower than their rated capacities.

8. Operators must read this manual in its entirety before using the Medium Brute. Eye and ear protection must be worn while operating the Medium Brute. Three safety stickers on the Medium Brute act as a reminder to these instructions. The symbols are defined in Figure 2.0-2 (on the next page).

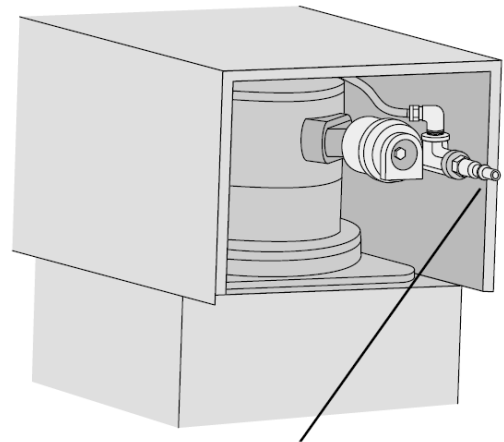

Figure 2.0-1
Location of Air Disconnect

Hydraulic Hose Safety

9. Inspect hydraulic hose for signs of wear (cuts, abrasions, or kinks) to the outer shell materials. Pump clean oil through the entire length. Pressurize the hose and check for leaks at the crimped connectors, between the hose material and the fitting, and between the fitting and the coupler.

10. **DO NOT** attempt to disconnect the hydraulic hose while it is under pressure.

11. **DO NOT** expose hoses to potential hazards such as extreme heat or cold, sharp surfaces, or heavy impact.

Read manual before using

Always wear eye protection

Always wear ear protection



**Figure 2.0-2
Safety Stickers**

12. **DO NOT** allow hoses to kink, twist, curl, or bend so tightly that the oil flow within the hose is blocked or reduced. Periodically inspect the hose and fittings for wear or damage that could cause premature failure of the hose or fittings and possibly result in injury. Damaged hoses must be replaced immediately.
13. **DO NOT** use the hose to move attached equipment.
14. **DO NOT** remove strain reliever from hoses.
15. Do not use in potentially explosive atmospheres.
16. Hose strain relievers must be placed around hose fittings during use. Hoses with damaged strain relievers must be replaced immediately.
17. Hose material and coupler seals must be compatible with hydraulic fluid that meets the requirements of U.S. MIL-SPEC #5606.
18. Hoses must not come in contact with toxic materials such as creosote-impregnated objects and some paints. Keep couplers and hoses clean and free of paint. Hose deterioration due to chemical degradation may cause the hose to fail under pressure. Damaged hoses must be replaced immediately.
19. Before operating pump, make sure all hose connections are tightened securely. **DO NOT** overtighten.
20. If hoses require replacement contact FTI Sales Department.

SECTION 3.0: PULLER UNIT OPERATING INSTRUCTIONS

Become familiar with these instructions before operating the puller.

3.1 PULLER UNIT SETUP PROCEDURE

Refer to Section 6.0 (Illustrated Parts Breakdown) for parts identification.

1. Inspect all threads and fittings of PowerPak for signs of wear or damage and replace them if necessary.
2. Uncoil the hose assembly of the puller unit, and inspect all threads, couplings, and hoses for damage and degradation.
3. Remove the thread protectors from the hydraulic fittings and thread the hydraulic hose fitting from the puller unit (female) onto the hydraulic fitting of the FTI PowerPak (male). Wipe fittings clean prior to connecting. Make sure to thread couplers completely together. There should be positive contact between the PowerPak coupler and the hose fitting flange. Failure to completely tighten the coupler will prevent the puller from returning to the forward (start) position. See Section 5.0, Problem 5.2, for more information.
4. Connect the male/female AIR quick-disconnects from puller to FTI PowerPak.
5. Test shop air supply to ensure that it is clean, dry, and between 90 and 120 psi (6.2 and 8.3 bar) at 45 cfm (1274.3 liter/minute).
6. Connect the female quick-disconnect of a 3/8-inch or 1/2-inch (9.5 mm or 12.7 mm) inside diameter shop air line onto the male air inlet of the PowerPak.
7. Install appropriate mandrel into threaded adapter (hand tight).
8. Install appropriate nosecap assembly over mandrel and thread onto barrel (hand tight).

3.2 ACTUATION OF THE PULLER

1. The puller can be activated only when connected to an FTI PowerPak.
2. Activate the puller by depressing the trigger on the handle. Hydraulic pressure is transmitted through the hose to the cylinder of the puller which then retracts the hydraulic piston.
3. Releasing the trigger changes pressure at the pilot valve and stops the pull cycle, and returns puller to original position.
4. If the puller fails to operate as detailed above, refer to Section 5.0 (Troubleshooting).

This page is intentionally left blank for two-sided printing.

SECTION 4.0: MAINTENANCE

The puller requires routine checking and periodic preventative maintenance to ensure safe, trouble-free operation. No special maintenance is required. The following maintenance actions are suggested.

WARNING
Disconnect the PowerPak from the air supply before performing maintenance or repair procedures.

4.1 GENERAL CLEANING

1. Periodically clean the outer surfaces of the puller unit and PowerPak.
2. When not in use, ensure thread protectors are reinstalled.
3. Keep all hose connections free of dirt and grime.

4.2 LUBRICATION

1. There is no internal lubrication requirement for the puller unit.
2. Whenever the puller is to be stored for any length of time, maintain a thin coat of 10-weight oil on the outside of black oxidized surfaces.

4.3 INSPECTION

Periodically inspect the threaded fittings for cracks, leaks or other damage. Repair and replace as necessary.

4.4 ASSEMBLY AND DISASSEMBLY

Normal replacement of seals (refer to the Illustrated Parts Breakdown, Figure 6.4-1).

Disassembly

1. Unthread and remove nose cap assembly.
2. Unthread and remove mandrel from threaded adapter.
3. Loosen lockring (7) to remove tension from end cap (6) and cylinder (3).
4. Unthread and remove end cap (6).
5. Unscrew and remove rear cylinder (3) and front cylinder (5) from housing (2).
6. Unthread and remove threaded adapter (8).

7. Unthread and remove the adapter (8) from the piston rod. Since it is necessary to hold the piston rod stationary to remove the lock nut (10), use a screwdriver in the slot (some old models have a hex wrench hole) in the back end of the piston, to keep the piston rod from turning.

DO NOT scratch the piston shaft during disassembly.

Note: Your MB was shipped with a 5/8-inch (15.9 mm) diameter threaded adapter installed and a 7/8-inch (22.2 mm) diameter threaded adapter.

8. Remove the piston rod assembly (4) by pushing on the threaded end (nosecap end) of the piston rod until threads engage the sleeve (2). Thread the piston rod through the sleeve and remove the piston rod assembly.
9. Remove the brass sleeve (2).
10. Remove the handle assembly (12) by removing four hex-head bolts.

Reassembly

**Important: (1) Thoroughly clean all parts prior to reassembly.
(2) Install O'Rings toward hydraulic flow, with Teflon backup rings "behind."**

1. Replace O'Rings and backup rings on the brass sleeve (2). Drop into front of housing (9).
2. Replace MB rear cylinder (3) and tighten until snug. Tighten the lock ring (7).
3. Replace O'Rings and backup rings on air seal adapter on end of piston assembly (4).
4. Install threaded end of piston assembly (4) into housing (9). Thread piston through housing and push to full forward position.
5. Install handle assembly (12) onto housing using four hex-head bolts.
6. Install threaded adapter (10).
7. Install front barrel (5).
8. Install end cap (6) and tighten lock ring (7).
9. Select appropriate mandrel/nosecap combination and install.

SECTION 5.0: TROUBLESHOOTING

This section provides solutions to some basic trouble spots. If you cannot solve your maintenance or operational problems with the information provided in this section, contact the nearest FTI representative.

Note: Should difficulties originate in the PowerPak, consult the specific PowerPak Operations, Maintenance, and Repair Manual.

<u>PROBLEM</u>	<u>CAUSE</u>	<u>SOLUTION</u>
----------------	--------------	-----------------

5.1 POWERPAK WILL NOT BUILD FULL HYDRAULIC PRESSURE

- | | |
|--|--|
| (a) One or more of the key air or hydraulic lines has not been securely connected. | (a) Check the following hose connections: <ol style="list-style-type: none">1. Male air line quick-disconnect fitting from shop air system to PowerPak.2. Hydraulic quick couplings connecting the hoses to the PowerPak manifold, and the puller to the hydraulic hoses.3. Two male/female air line quick-disconnect fittings connecting the puller to the PowerPak manifold.4. Check that the main air supply has not been interrupted. |
|--|--|

CAUTION

Hydraulic oil under extreme pressure may cause serious injuries if not handled carefully. For technical assistance, please contact the FTI Technical Sales Department.

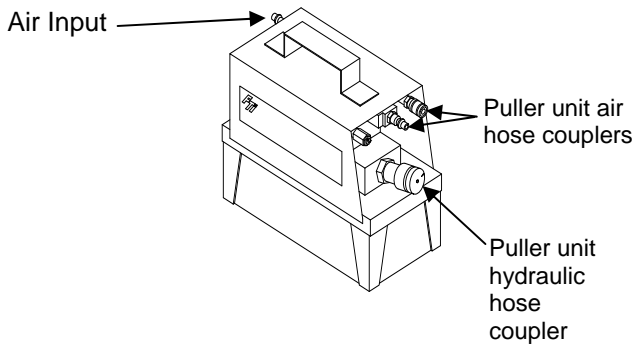

**Figure 5.1-1
FT-20 PowerPak***

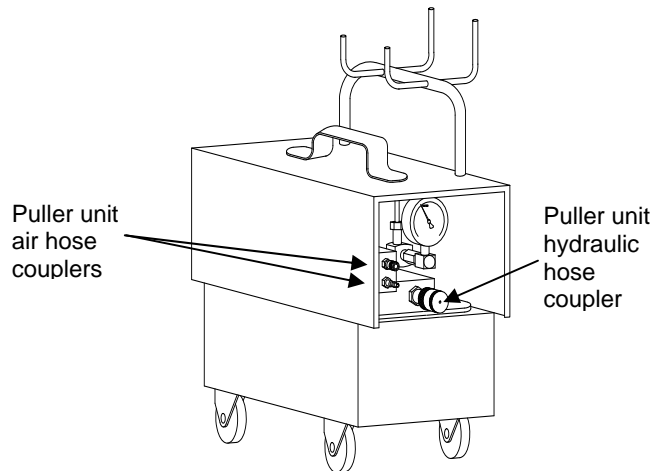

**Figure 5.1-2
FT-200 PowerPak***

* PowerPak drawings are not to scale.

PROBLEM

CAUSE

SOLUTION

5.2 PULLER RETRACTS ON FIRST TRIGGER ACTUATION, BUT WILL NOT RETURN TO START POSITION

- | | | |
|---|---|---|
| <p>(a) The new puller unit requires lubrication through the piston and cylinder.</p> | <p>(a) Cycle trigger several times to introduce hydraulic fluid into the cylinder.</p> | |
| <p>(b) As above, AND the hydraulic hose is difficult to bend or coil (indicating unrelieved pressure built up in the hose).</p> | <p>(b) The hydraulic quick coupler line has not been completely tightened at the PowerPak manifold (there should be no space between the PowerPak coupler and the hose fitting flange). See Figure 5.2-1.</p> | <p>(b) Once hydraulic pressure has been introduced to the hydraulic hose, the pressure must be relieved before the coupler can be sufficiently tightened.</p> |

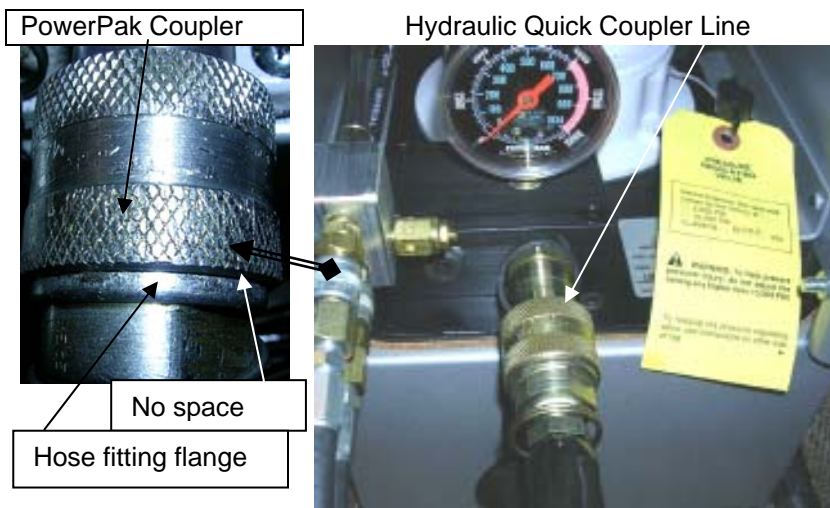

**Figure 5.2-1
Hydraulic Quick Coupler**

Procedure for relieving hydraulic pressure:

1. Disconnect main air supply.
2. Disconnect coupler from PowerPak.
3. Wrap the fitting with a rag to absorb the squirting oil and slowly turn the coupler off the hydraulic hose to allow hydraulic oil to bleed out.
4. Once pressure is relieved, coupler may be tightened and reinstalled onto PowerPak.
5. Re-attach air lines to get puller to return.

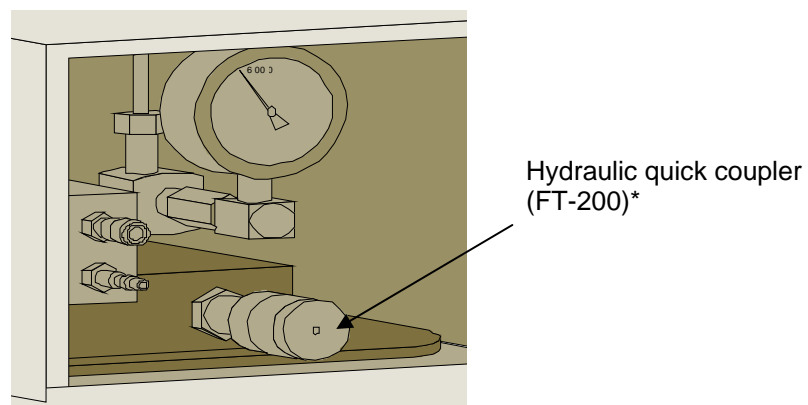

**Figure 5.2-2
Hydraulic Quick Coupler Location
(FT-200)**

*Drawings not to scale

PROBLEM

CAUSE

SOLUTION

5.3 POWERPAK WILL NOT GENERATE CONSTANT PRESSURE (HICCUPS)

(a) Trigger response valve requires adjustment.

(a) Adjustment procedure:

1. Loosen locknut on trigger response valve.
2. Using a screwdriver, open screw counterclockwise until PowerPak will not start when puller trigger is depressed.

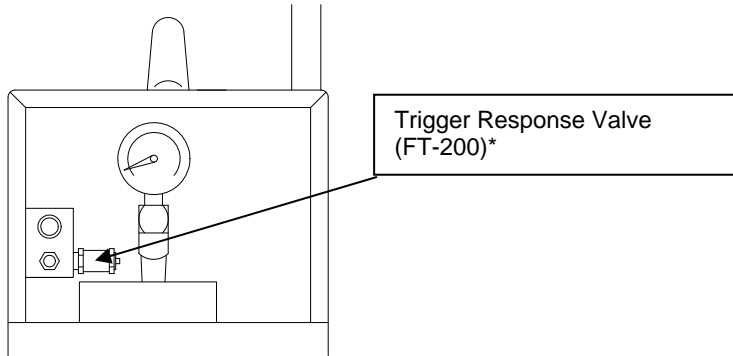

**Figure 5.3-1
Trigger Response Valve (FT-200) Location**

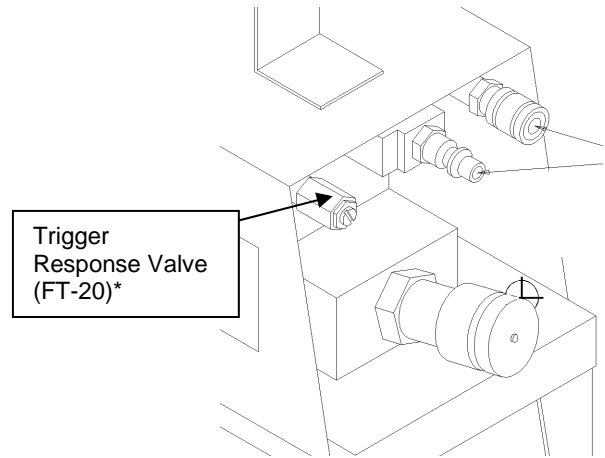

**Figure 5.3-2
Trigger Response Valve (FT-20) Location**

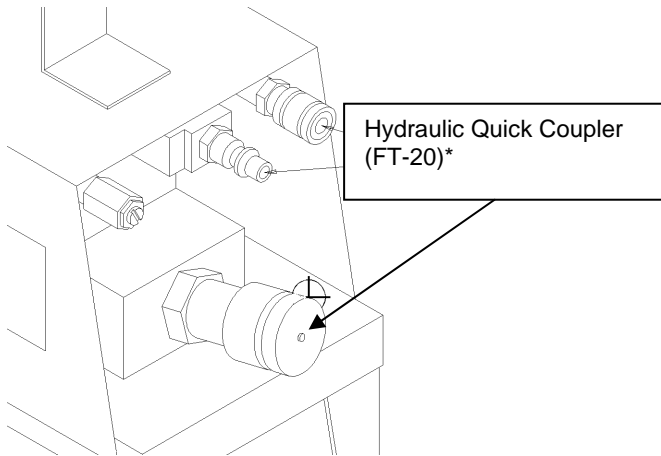

**Figure 5.3-3
Hydraulic Quick Coupler (FT-20) Location**

3. Turn screw clockwise until:
 - PowerPak generates constant pressure when puller trigger is depressed, and
 - PowerPak starts instantly when puller trigger is depressed and stops instantly when released. When the puller trigger is depressed, the PowerPak should be run at the pre-set pressure until the trigger is released.
4. Hold set screw in position and tighten locknut.

*PowerPak drawings are not to scale.

**5.4 POWERPAK WILL NOT OPERATE OR MAINTAIN SUFFICIENT PRESSURE
(6,000 PSI, 413.7 BAR)**

(a) Hydraulic pressure requires adjusting (applicable to FT-200 PowerPak only).

(a) Adjust PowerPak pressure valve:

1. Squeeze trigger on puller unit to activate PowerPak.
2. If pressure does not reach 6,000 psi (413.7 bar), loosen wingnut and turn hydraulic pressure control clockwise until pressure reaches 6,000 psi (413.7 bar).
3. Tighten locknut to secure available shop air.

(b) Inadequate air supply.

(b) Increase pressure or flow of available shop air.

If the PowerPak will not generate or maintain sufficient pressure, the main air line pressure is too low or the PowerPak hydraulic pressure requires adjustment.

Air pressure requirements:

-1/2-inch (12.7 mm) inside diameter air line with 90 to 120 psi for the FT-200

-3/8-inch (9.5 mm) inside diameter air line with 90 to 120 psi (6.2 to 8.3 bar) for the FT-20

Flow requirements:

-40 to 50 cfm (1274.3 to 1415.9 liter/minute for the FT-200

-20 cfm (566.3 liter/minute for the FT-20

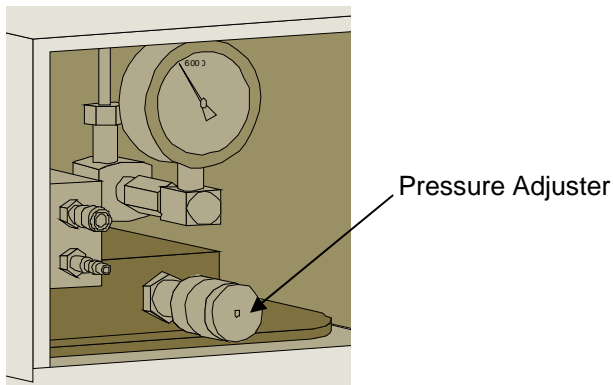

**Figure 5.4-1
Pressure Gauge (FT-200) Location**

*

PROBLEM

CAUSE

SOLUTION

5.5 MANDREL STICKS IN THE HOLE WHEN PULLER ACTIVATED

(a) Not enough pressure used to generate pull forces. If Medium Brute is being used with an FT-20 PowerPak, proceed to solution 4.

(a) Use the following procedure to analyze the problem:

1. Actuate the puller and observe pressure reading on PowerPak pressure gage (FT-200 PowerPak only).
2. Pressure gage should read 6,000 psi (413.7 bar). (Note: FT-20 PowerPak is factory set at 10,000 psi or 689.5 bar). If an increase in pressure is required, refer to the solution for Problem 5.4 in this section for instructions.
3. Actuate puller again. If mandrel remains stuck, increase pressure to 10,000 psi (689.5 bar).
4. If mandrel remains stuck at 10,000 psi (689.5 bar), immediately disengage the mandrel from the puller. Push the mandrel out using an impact hammer. Contact the FTI Technical Sales Department for additional assistance.

This page is intentionally left blank for two-sided printing.

SECTION 6.0: ILLUSTRATED PARTS BREAKDOWN

FTI has redesigned the puller unit trigger assembly, built with serial number 810 or higher, to a cartridge trigger assembly. The new design will reduce the occurrence of trigger air leaks, perform more reliably (better pump actuation), and be easier to maintain. The previous trigger design as detailed in Section 6.3 can be easily replaced with the Cartridge Trigger Assembly Kit (FTI-CT-RK) or the Medium Brute Rework Kit (MB-CT-RK) and the Puller Trigger Rework Tool Kit (FTI-CT-RKT). One FTI-CT-RK or MB-CT-RK is required for each puller converted. Only one FTI-CT-RKT is required regardless of the number of pullers converted. The FTI-CT-RKT kit also includes detailed instructions on how to perform the modification.

6.1 MEDIUM BRUTE REWORK KIT (MB-CT-RK)

This kit is used to repair or refurbish older pullers. Table 6.1-1 is a parts list for the Medium Brute Rework Kit and Figure 6.1-1 shows a diagram of the cartridge trigger assembly.

Table 6.1-1
Medium Brute Rework Kit (MB-CT-RK)

Quantity	Piece Number	Description	FTI Part Number
1		Screw, SHG (10-32 UNFX 3/4)	1029-005
1		MB-H-D16 Hydraulic Adapter	2039-002
1		Medium Brute Seal Kit (MB-SK) (See Section 6.2)	8000-485
1	2	Push Button, Brass	1187-623
1	3	Retaining Ring, Internal	1187-624
1	4	Sleeve, Puller Handle Trigger	3196-001

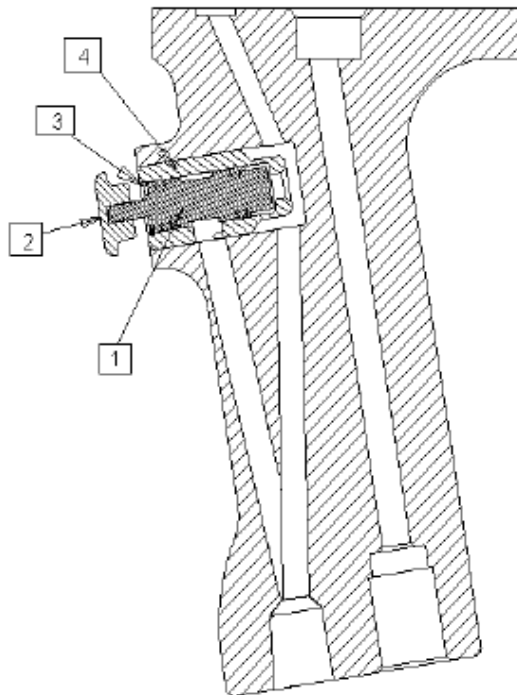

Figure 6.1-1
Diagram of Cartridge Trigger Assembly

6.2 MEDIUM BRUTE SEAL KIT (MB-SK)

This kit is used to replace seals. It is included as part of the Medium Brute Rework Kit (see Section 6.1). Table 6.2-1 is a parts list for the Medium Brute Seal Kit.

**Table 6.2-1
Medium Brute Seal Kit (MB-SK)**

Quantity	Description	FTI Part Number	Piece Number
1	Valve, Cartridge Trigger (See Figure 6.1-1, Piece Number 1)	1187-622	
1	Seal, LB Handle (See Table 6.3-1, Piece Item 6)	2040-001	
2	Ring, Backup MS28782-7	1046-044	1
2	O'Ring AN6227B-7	1046-045	2
1	O'Ring AN6227B-3	1046-012	3
1	O'Ring MS28775-224	1046-058	4
1	O'Ring AN6227B-17	1046-002	5
2	MS2878217 Ring, Backup	1046-003	6
1	17149-122	1046-043	7
1	A-122-90-BUNA	1046-007	8
1	AN6227-28	1046-004	9
1	MS28782-28	1046-005	10
1	T-Seal TPO23	1046-113	11

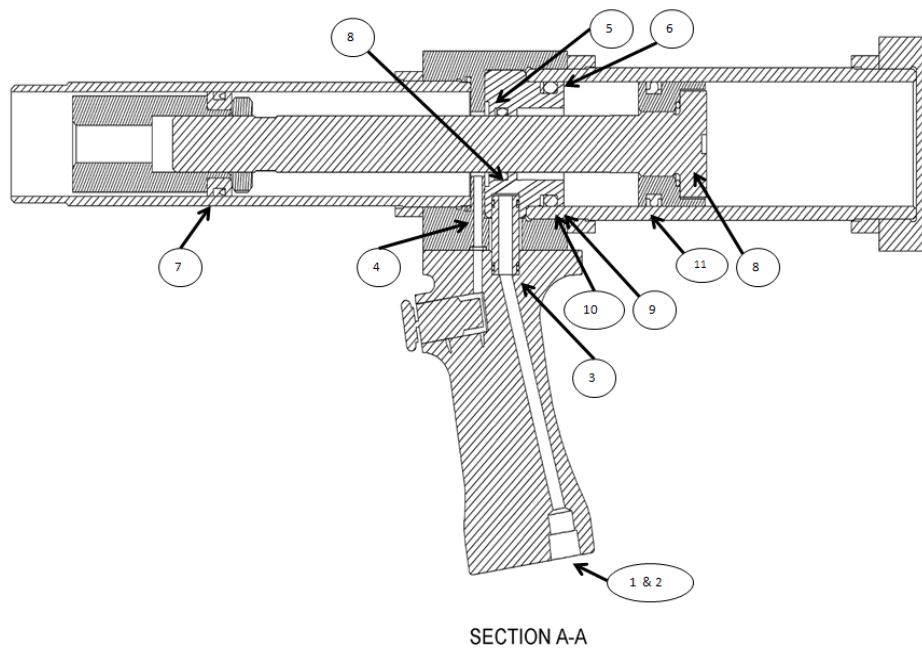

**Figure 6.2-1
Medium Brute Seal Kit**

6.3 PREVIOUS TRIGGER ASSEMBLY

The previous trigger design (serial numbers smaller 810) detailed here can be easily replaced with the improved trigger assembly detailed in Section 6.1. Table 6.3-1 is a parts list for the old-style trigger assembly.

**Table 6.3-1
Parts List for Previous Trigger Assembly**

Quantity	Piece Item	Description	FTI Part Number
1	1	Trigger, LB Handle	2042-001
1	2	Spring, LB Handle	1005-003
1	3	Retainer, LB Handle	2043-001
1	4	Ball, .250 Diameter, stl.	1045-025
1	5	Pin, 1/8 x 3/4 stdl. Spring	1045-026
1	6	Seal, LB Handle	2040-001
1	7	Sleeve, LB Handle	2044-001

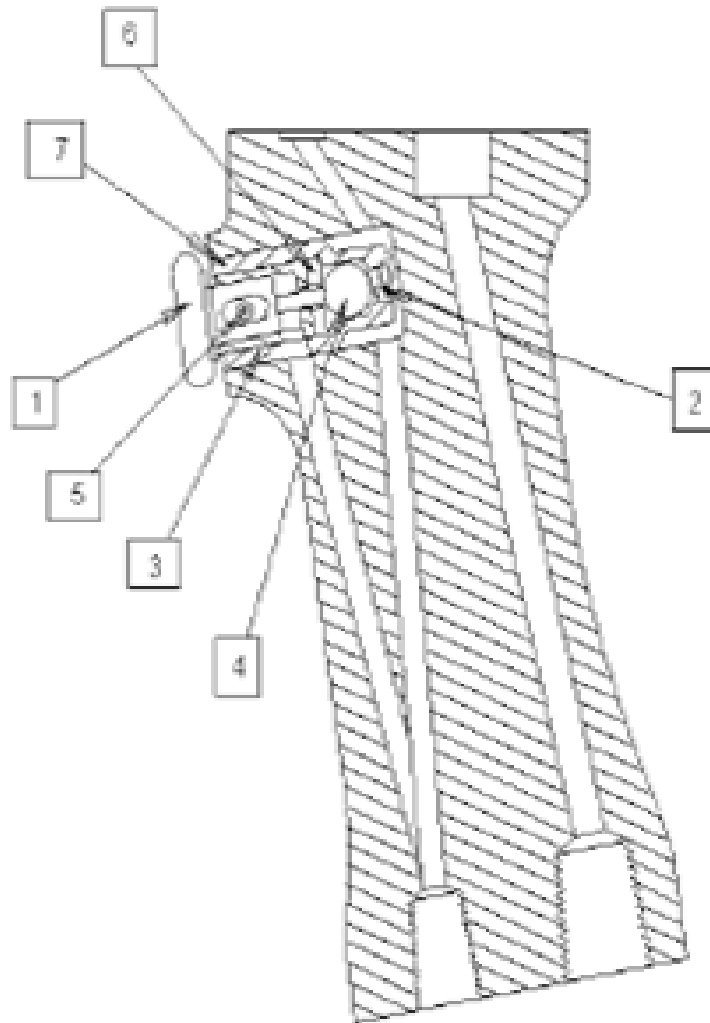

**Figure 6.3-1
Diagram of Previous Trigger Assembly**

6.4 MEDIUM BRUTE PARTS LIST

**Table 6.4-1
Medium Brute Parts List**

Reference Number	Description	Part Number	Reference Information
2	Sleeve	2349-001	MB-D2
3	Cylinder	2184-00*	MB-**-D3
4	Piston Assembly	2405-00*	MB-**-D4
5	Barrel	2332-00*	MB-**-D5
6	End Cap	2136-002	MB-D6
7	Cylinder Lockring	2120-002	MB-D7
8	Chuck Assembly Adapter	2491-00* 2425-001	MB-CA-** MB-D17
9	Housing	2350-001	MB-D10
10	Locknut Adapter	2422-001	MB-D14
11	Barrel Lockring	2120-004	MB-D16
12	Handle Assembly	2049-002	MB-H-1
13	Hydraulic Hose Assembly	2107-001	IWHH-10
14	O'Ring	1046-002	AN6227-17
15	Backup Ring	1046-003	MS28782-17
16	O'Ring	1046-004	AN6227-28
17	Backup Ring	1046-005	MS28782-28
18	O'Ring	1046-058	MS28775-224
19	O'Ring	1046-007	A-122-90-BUNA
20	Warning Label	1009-185	--
21	FTI Label	1009-094	--
22	Do Not Strike Label	1009-184	--
23	Heat Shrink Tube	2638-001	3" Long
24	Air Hose Assembly (Male)	2106-001	IWAH-10
25	Air Hose Assembly (Female?)	2106-002	IWAH-10
26	MB Puller Label	1009-187	--

* = Indicates part numbers dependent on Medium Brute model number (-30 or -70). Contact FTI Technical Sales for assistance.

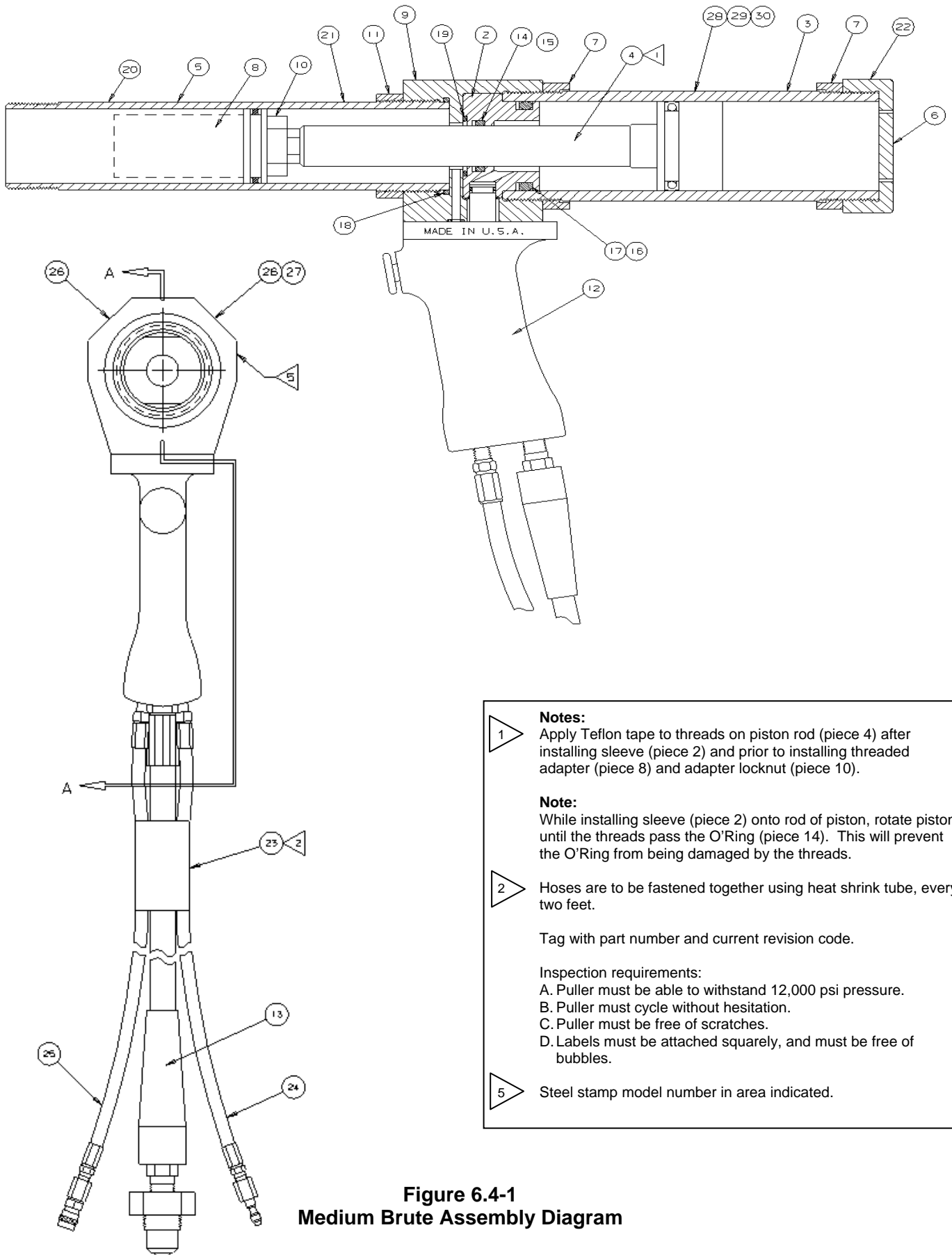

- Notes:**
- 1 Apply Teflon tape to threads on piston rod (piece 4) after installing sleeve (piece 2) and prior to installing threaded adapter (piece 8) and adapter locknut (piece 10).
- Note:**
- While installing sleeve (piece 2) onto rod of piston, rotate piston until the threads pass the O'Ring (piece 14). This will prevent the O'Ring from being damaged by the threads.
- 2 Hoses are to be fastened together using heat shrink tube, every two feet.
- Tag with part number and current revision code.
- Inspection requirements:
- A. Puller must be able to withstand 12,000 psi pressure.
 - B. Puller must cycle without hesitation.
 - C. Puller must be free of scratches.
 - D. Labels must be attached squarely, and must be free of bubbles.
- 5 Steel stamp model number in area indicated.

**Figure 6.4-1
Medium Brute Assembly Diagram**

This page intentionally left blank for two-sided printing.