

FTI OPERATIONS, MAINTENANCE, AND REPAIR MANUAL

Little Brute Puller Unit

FTI Part #2720-006, Log #1151
Revision D

July 8, 2011



ABOUT FATIGUE TECHNOLOGY

Fatigue Technology (FTI) is a world-leading aerospace engineering and manufacturing company. FTI pioneered Cold Expansion (CX™) technology (which provides solutions to fatigue problems associated with holes in metal structures) back in 1969 and has advanced this science to develop innovative bushing and fastener products. These proprietary products and associated tooling may be covered by patents or agreements owned by, or exclusively licensed to Fatigue Technology. Use of tooling procured from other than a licensed source may constitute patent infringement.

The detailed tooling information in this manual was compiled and written by FTI. The tooling was designed specifically for use with FTI's Cold Expansion Systems. FTI cannot be held responsible for damage or injury as a result of operating this equipment if it is used for other than the process intended, with any other tooling not provided by FTI, or not used in accordance with the instructions contained in this manual. To avoid personal injury, please observe all safety precautions and instructions. FTI reserves the right to change specifications or configurations of equipment detailed in this manual as part of our ongoing technical and product improvement programs. If you have any questions about the use or serviceability of this equipment, please contact our Technical Sales Department.

FTI's Cold Expansion™ systems and processes are the subject matter of one or more of the following patents: 4,809,420; 4,885,829; 4,934,170; 5,083,363; 5,096,349; 5,103,548; 5,127,254; 5,129,253; 5,218,854; 5,245,743; 5,305,627; 5,341,559; 5,380,136; 5,405,228; 5,433,100; 5,468,104; 6,077,010; 6,183,180; 6,487,767; 6,792,657; 6,990,722; 7,024,908; 1,061,276; 513,898; 692015124; 581,385; 69310828; 468,598; 69105390; 643,231; 69414946; 696,686; 785,366; 1032769; and other patents pending. These systems and processes are tooling critical and must be performed in accordance with FTI's specifications or controlling documents. To ensure proper results from FTI's cold expansion systems and to be licensed to use FTI's patented processes, it is essential that FTI's complete integrated system of tooling be purchased and utilized. The use of tooling purchased from other than a licensed supplier could jeopardize fatigue life enhancement and may constitute patent infringement.

Fatigue Technology (FTI) has provided innovative solutions to fatigue problems in metal structures since 1969. Complete systems of tooling are used worldwide to enhance the fatigue life of holes in airframes, turbine engines, and other critical structures.

The FTI staff of professionals provides a full range of support services including:

- Application engineering
- Detailed project planning, implementation and management
- On-site assistance, including training and tool room setup

Complete inventory allows FTI to respond quickly to customers' requirements.

The Sales Department is always available to assist with special fatigue enhancement requirements. Please contact FTI with questions at any time.

This manual can be made available in other languages. Please contact the Sales Department to request a copy.

TABLE OF CONTENTS

SECTION	DESCRIPTION	PAGE
1.0	Introduction.....	1
1.1	About the Little Brute Puller Unit	1
1.2	General Description.....	1
1.3	General Specifications.....	2
2.0	Safety	5
3.0	Puller Unit Operating Instructions	9
3.1	Puller Unit Setup Procedure and Operation	9
3.2	Activation of Puller Unit	9
4.0	Puller Unit Maintenance	11
4.1	General Cleaning.....	11
4.2	Lubrication	11
4.3	Inspection	11
4.4	Disassembly.....	11
4.5	Re-assembly	13
5.0	Troubleshooting	15
6.0	Illustrated Parts Breakdown.....	19
6.1	Little Brute Rework Kit; Parts List and Diagram.....	20
6.2	Little Brute Seal Kit; Parts List and Diagram.....	21
6.3	Previous Little Brute Trigger Assembly; Parts List and Diagram.....	22
6.4	Little Brute Puller Assembly; Parts List and Diagram	23

FIGURES

Figure 1.3-1	Little Brute Puller Unit Parts	2
Figure 1.3-2	Little Brute Specifications	3
Figure 2.0-1	Location of Air Disconnect.....	5
Figure 2.0-2	Safety Stickers	6
Figure 6.1-1	Diagram of Little Brute Rework Kit Parts (LB-CT-RK)	20
Figure 6.2-1	Diagram of Little Brute Assembly (LB-SK).....	21
Figure 6.3-1	Diagram of Previous Little Brute Trigger Assembly	22
Figure 6.4-1	Little Brute Assembly	23

TABLE OF CONTENTS (Continued)

SECTION	DESCRIPTION	PAGE
TABLES		
Table 6.0-1	Trigger Assembly Conversion	19
Table 6.1-1	Parts List for Little Brute Rework Kit (LB-CT-RK)	20
Table 6.2-1	Little Brute Seal Kit (LB-SK)	21
Table 6.3-1	Previous Little Brute Trigger Assembly	22
Table 6.4-1	Little Brute Parts List.....	24

SECTION 1.0: INTRODUCTION

This instruction manual contains information on the operation and maintenance of the Little Brute (LB) Puller Unit. To obtain optimum performance and many years of trouble-free service, operate the puller unit properly and carefully follow maintenance procedures.

Read this manual before operating the puller unit and retain it for future reference.

1.1 ABOUT THE LITTLE BRUTE PULLER UNIT

The Little Brute hydraulic puller unit is a powerful, small, lightweight tool specifically designed for use with Fatigue Technology (FTI) patented Split Sleeve Cold Expansion™ (SsCx™) process. The Little Brute Puller Unit is designed to pull a mandrel through a hole with the pre-lubricated stainless steel split sleeves used in this process.

The Little Brute puller has a maximum pull force of 8,000 pounds (35,584N) at 10,000 psi (68.95MPa) pump pressure. The Little Brute is available in six sizes (models) for cold expanding holes up to 1/2 inch (12.7mm) in diameter and 3-1/2 inches (88.9mm) deep in aluminum, and 3/8 inch (9.53mm) in diameter and 3-1/2 inches (88.9mm) deep in steel and titanium.

The Little Brute is available in various models to accommodate multiple material stack-ups, including “-V” models with high-visibility hose markings.

The Little Brute has a fail-safe air control system that causes the puller retraction cycle to be interrupted whenever the operator releases finger pressure on the trigger or in the event of air or hydraulic hose failure. All puller units operate in conjunction with either of FTI's PowerPak air-hydraulic power units, the standard FT-200 or portable FT-20 (and compatible with older units IW100MF and IW10MF). The Little Brute has proven to be very reliable and requires minimal maintenance.

1.2 GENERAL DESCRIPTION

NOTE: Specifications are the same for all Little Brute pullers LB-10 through LB-35.

Hydraulic Fluid Requirements.....	U.S. MIL-SPEC #5606
Operating Hydraulic Pressure.....	10,000 psi (68.95MPa)
Pull Force Capacity.....	8,000 pounds (35,584N)
PowerPak Air Line Requirements	3/8 inch to 1/2 inch (9.53 to 12.70mm) ID (FT-200)
PowerPak Air Flow Requirements.....	90 to 120 psi (.621 to .827MPa), 50 cfm (1.42m ³ /min) (FT-200)
Actuation.....	Pneumatic
Operation	Hydraulic
Compatible PowerPaks	FT-200 or FT-20
Fail-Safe.....	Air logic safety circuit halts mandrel retraction when trigger is released
Replacement Seal Kit.....	LB Seal Kit (LB-SK)

1.3 GENERAL SPECIFICATIONS

The LB-20 Puller is the preferred model by most customers since material stack-ups rarely exceed two inches (50.8mm) in the applicable diameter range.

Nosecap Selection: The Little Brute is compatible with both the standard nose cap (Section 2, page 63)* or the flush nose caps (Section 2, page 69)*.

Mandrel Selection: The Little Brute is directly compatible with standard Type 1, 7/16-20 threaded mandrels (Section 2, pages 54 to 55)*. The LB may also be adapted to tang or pintail mandrels using LB-CA and LB-PC chuck assemblies, respectively.

*Page refers to FTI's comprehensive Tooling Catalog.

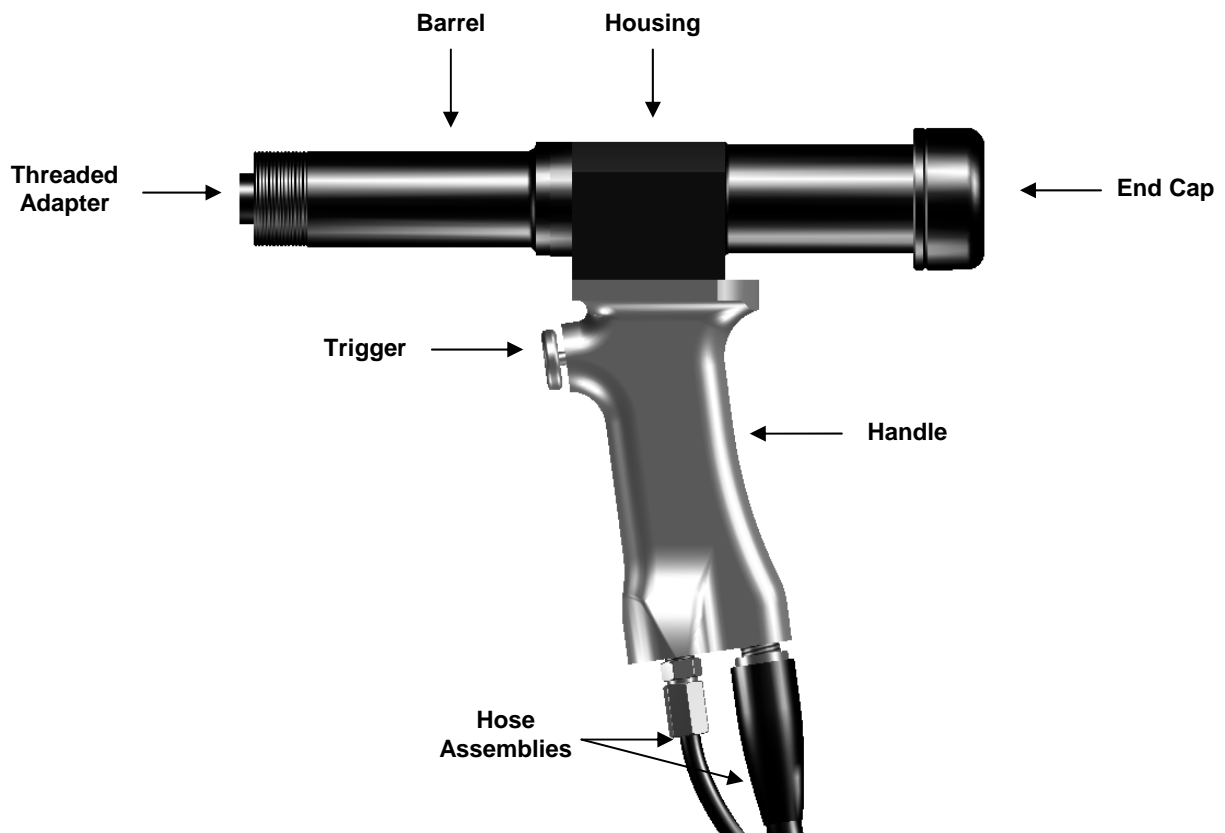

**Figure 1.3-1
Little Brute Puller Unit Parts**

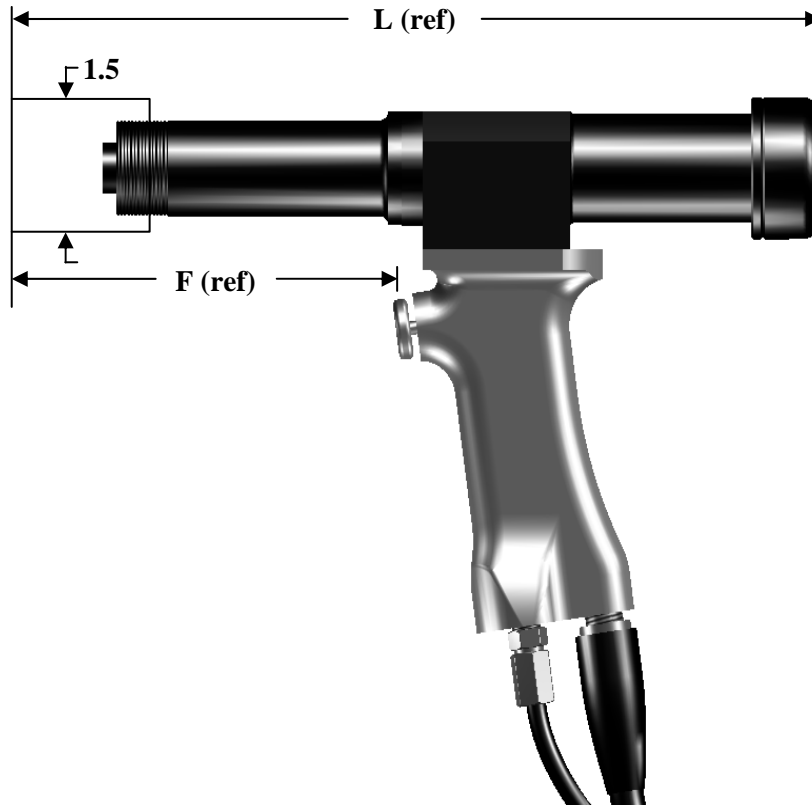

Model Number	Maximum Material Stackup (inch)	L (inch)	F (inch)	Weight (lb.)	Stroke (inch)
LB-10	1.0 (25.4mm)	9.2 (233.7mm)	4.0 (101.6mm)	10.75 (47.8N)	2.0 (50.8mm)
LB-15	1.5 (38.1mm)	10.2 (259.1mm)	4.5 (114.3mm)	11.00 (48.9N)	2.6 (66.0mm)
LB-20	2.0 (50.8mm)	11.2 (284.5mm)	5.0 (127.0mm)	11.25 (50.0N)	3.1 (78.7mm)
LB-20-FVC	2.0 (50.8mm)	11.2 (284.5mm)	5.0 (127.0mm)	11.25 (50.0N)	3.1 (78.7mm)
LB-20-FVS	2.0 (50.8mm)	11.2 (284.5mm)	5.0 (127.0mm)	11.25 (50.0N)	3.1 (78.7mm)
LB-25	2.5 (63.5mm)	12.2 (309.9mm)	5.5 (139.7mm)	11.50 (51.2N)	3.6 (91.4mm)
LB-30	3.0 (76.2mm)	13.2 (335.3mm)	6.0 (152.4mm)	11.75 (52.3N)	4.1 (104.1mm)
LB-35	3.5 (88.9mm)	14.2 (360.7mm)	6.5 (165.1mm)	12.00 (53.4N)	4.6 (116.8mm)

**Figure 1.3-2
Little Brute Specifications**

This page intentionally left blank for two-sided printing.

SECTION 2.0: SAFETY

When used in accordance with these instructions, the puller unit is safe and easy to use. All general safety precautions associated with hydraulic and pneumatically operated power tools should be observed. Many of these are noted in this section.

Ultimately, operators are responsible for their own safety; however, the following general safety precautions should be observed.

1. Wear eye protection when operating the puller unit.
2. Disconnect the air supply when:
 - Maintenance is to be performed
 - Hydraulic hose is disconnected
 - PowerPak is not in use
3. In the event of a ruptured or leaking hydraulic hose, **IMMEDIATELY RELEASE THE TRIGGER AND DISCONNECT THE AIR LINE** at the air coupler from the PowerPak (see Figure 2.0-1). Never use your hands to grasp a leaking hose under pressure. The force of escaping hydraulic fluid could cause serious injury.
4. Keep hands away from nosecap assembly while holding nosecap against the workpiece.
5. Release puller unit trigger when mandrel clears the workpiece or **BECOMES STUCK**.
6. End cap must always be in place while in use. Injury may occur if end cap is removed during operation. All new Little Brute Puller Units have been modified to ensure operator safety. However, rework instructions are available from FTI for any Little Brute Puller Units that don't have a roll pin and air seal adapter, like that shown in Figure 6.4-1.
7. Before operating the pump, tighten all hose connections using the proper tools. Do not over tighten the connections. Connections need only be tightened securely and leak-free. Over tightening may cause premature thread failure or high-pressure fittings to split at pressures lower than their rated capacities
8. Operators must read this manual in its entirety before using the Little Brute. Eye and ear protection must be worn while operating the Little Brute. Three safety stickers on the Little Brute act as a reminder to these instructions. The symbols are defined in Figure 2.0-2.
9. Do not use in potentially explosive atmospheres.

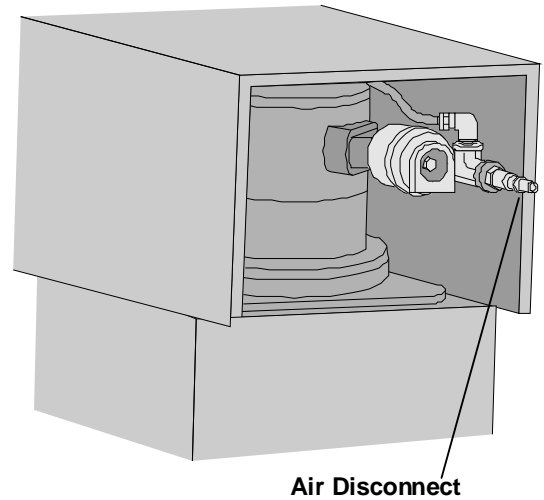
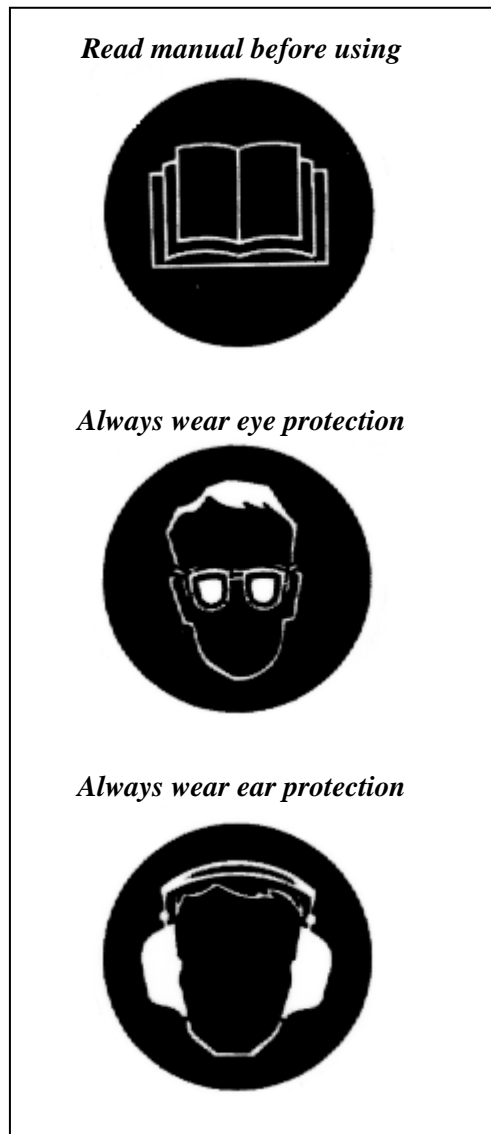

Figure 2.0-1
Location of Air Disconnect



**Figure 2.0-2
Safety Stickers**

Hydraulic Hose Safety

10. Inspect hydraulic hose for signs of wear (cuts, abrasions or kinks) to the outer shell material. Pump clean oil through the entire length. Pressurize the hose and check for leaks at the crimped connectors, between the hose material and the fitting, and between the fitting and the coupler
11. DO NOT attempt to disconnect the hydraulic hose while it is under pressure.
12. DO NOT expose hoses to potential hazards such as extreme heat or cold, sharp surfaces or heavy impact.
13. DO NOT allow hoses to kink, twist, curl, or bend so tightly that the oil flow within the hose is blocked or reduced. Periodically inspect the hose for wear or damage that could cause premature failure of the hose and possibly result in injury. Damaged hoses must be replaced immediately.
14. DO NOT use the hose to move attached equipment.

15. DO NOT remove strain reliever from hoses.
16. Hose strain relievers must be placed around hose fittings during use. Hoses with damaged strain relievers must be replaced immediately.
17. Hose material and coupler seals must be compatible with hydraulic fluid that meets the requirements of US MIL-SPEC #5606.
18. Hoses must not come in contact with toxic materials such as creosote-impregnated objects and some paints. Keep couplers and hoses clean and free of paint. Hose deterioration due to chemical degradation may cause the hose to fail under pressure. Damaged hoses must be replaced immediately.
19. Before operating pump, make sure all hose connections are tightened securely. DO NOT over tighten.
20. If hoses require replacement, contact FTI Technical Sales Department.

This page is intentionally left blank for two-sided printing.

SECTION 3.0: PULLER UNIT OPERATING INSTRUCTIONS

Become familiar with these instructions before operating the puller.

3.1 PULLER UNIT SETUP PROCEDURE AND OPERATION

Refer to Section 6 (Illustrated Parts Breakdown) for parts identification.

1. Inspect all threads and fittings for signs of wear or damage and replace them if necessary.
2. Install appropriate mandrel in threaded adapter. Install proper chuck assembly in place of threaded adapter if tang or pintail mandrel is to be used.
3. Install appropriate nosecap assembly over mandrel and thread it into place.
4. Uncoil the hose assembly of the puller unit and inspect all threads, couplings and hoses for damage and degradation. Any damaged component must be replaced immediately.
5. Remove thread protectors from the hydraulic fittings and thread the hydraulic hose fitting from the puller unit (male) onto the hydraulic fitting of the FTI PowerPak (female). Wipe fittings clean prior to connecting.
6. Thread couplers completely together. There should be positive contact (no space) between the PowerPak coupler and the hose fitting flange. See Section 5, Problem 2 for more information. Failure to completely tighten the coupler will cause the puller piston to become stuck in the retracted position. Strain relievers must be placed on hose fittings during operation. If strain relievers are worn or damaged, they must be replaced immediately.
7. Connect the male/female AIR quick disconnects from the puller to the FTI PowerPak.
8. Test shop air to ensure that air is clean, dry, and between 90 and 120 psi (.621 and .827MPa) at 50 cfm (1.42m³/min).
9. Connect the female quick disconnect of a 1/2-inch (12.7mm) ID shop air line onto the male air inlet of the PowerPak.

3.2 ACTIVATION OF PULLER UNIT

1. The puller can be activated only when connected to an FTI PowerPak.
2. Activate puller by depressing the trigger on the handle. Hydraulic pressure is transmitted through the hose to the cylinder of the puller, which then retracts the hydraulic piston that performs the cold expansion procedure.
3. Releasing the trigger changes pressure at the pilot valve and stops the pull cycle. Air pressure returns the puller to original position.
4. If the puller fails to operate as detailed above, refer to Section 5 (Troubleshooting).

This page intentionally left blank for two-sided printing.

SECTION 4.0: PULLER UNIT MAINTENANCE

The puller requires routine checking and periodic preventative maintenance to ensure safe, trouble-free operation. No special maintenance is required. The following maintenance actions are suggested.

CAUTION: Before attempting any maintenance operations on the puller, disconnect the PowerPak from the air supply or disconnect the puller from the PowerPak or hand pump.

4.1 GENERAL CLEANING

1. Periodically clean the outer surfaces of the puller unit and PowerPak.
2. When not in use, ensure thread protectors are re-installed.
3. Keep all hose connections free of dirt and grime. Doing so will dramatically extend the life of pumps and puller seals.

4.2 LUBRICATION

1. There is no internal lubrication requirement for the puller unit.
2. Whenever the puller is to be stored for any length of time, maintain a thin coat of 10-weight oil on the outside of black oxide surfaces.

4.3 INSPECTION

1. Periodically inspect threaded fittings, hoses, and strain relievers for cracks, leaks or other damage. Repair and replace immediately.

4.4 DISASSEMBLY

Refer to Section 6.4 for parts lists unless otherwise noted. For Little Brute Puller Units below Serial #406, Step 7 will not be possible since air seal adapter is adhered to the piston rod. These two parts and the required seals are referred to as the piston rod assembly.

1. Unthread and remove nose cap assembly.
2. Unthread and remove mandrel from threaded adapter (8).
3. Loosen lockring (10) to remove tension from end cap (9).
4. Unthread and remove end cap (9).
5. Unscrew and remove barrel (4) from housing (2).
6. Unthread and remove threaded adapter (8) or chuck assembly if so equipped; use flats on back of threaded adapter (8) and mating air seal adapter (7).
7. Remove spring pin (26) (if present, see Figure 6.4-1). Unthread and remove air seal adapter (7).

NOTE: Since it is necessary to hold the piston rod stationary to remove the threaded adapter (10), use a screwdriver in the slot (some models may have a hex wrench hole) in the back end of the piston, to keep the piston rod from turning. **DO NOT** scratch the piston shaft during disassembly.

8. Remove the piston rod assembly (3, Figure 6.4-1) by pushing on the threaded end (nosecap end) of the piston rod until threads engage the sleeve (5, Figure 6.4-1). Thread the piston rod threads through the sleeve (5, Figure 6.4-1) and remove the piston rod assembly from the unit.
9. Using the pin wrench supplied, remove the sleeve retainer (6, Figure 6.4-1).
10. Remove the brass sleeve (5, Figure 6.4-1).

11. Remove the handle assembly (11, Figure 6.4-1) by removing four hex-head bolts.

Normal replacement of seals requires the use of Little Brute Seal Kit (LB-SK). Refer to Section 6.2.

12. Remove and replace the O-ring on the top face of the handle (4, Figure 6.2-1).
13. Remove hydraulic adapter (6, Figure 6.1-1); replace O-rings (3; Figure 6.2-1) and backup rings (2, Figure 6.2-1).
14. Replace hydraulic adapter (6, Figure 6.1-1) into handle (11, Figure 6.4-1).
15. Remove and replace O-ring (6, Figure 6.2-1) and backup ring (7, Figure 6.2-1) on outside diameter of sleeve (5, Figure 6.4-1).
16. Remove and replace O-ring (8, Figure 6.2-1) and backup ring (9, Figure 6.2-1) on inside diameter of sleeve.
17. Replace omni seal (10, Figure 6.2-1) on air seal adapter (1, Figure 6.1-1).
18. Remove and replace O-ring (6, Figure 6.2-1) and backup ring (7, Figure 6.2-1) on piston rod assembly.
19. Remove and replace O-ring (5, Figure 6.2-1) on barrel.

4.5 RE-ASSEMBLY

Refer to Section 6 for parts lists. All numbers below refer to location numbers in Figure 6.4-1.

IMPORTANT: 1. Thoroughly clean all parts prior to reassembly.
2. Check to see if O-rings are installed toward hydraulic flow with Teflon backup rings behind.

1. Place sleeve (5) into front of housing (2) as shown (note orientation).
2. Replace puller unit sleeve retainer (6) and tighten until snug.
3. Install piston assembly (3) into housing (2) by gently threading the piston through the sleeve (5). Then push the piston (3) to full forward position. Lubricating piston rod and threads with hydraulic oil will help prevent damage to the sleeve seals.
4. Install handle assembly (11) with hydraulic adapter onto housing (2) using four hex-head bolts. Teflon backup rings (2, Figure 6.2-1) may be partially sheared off during the installation process. Remove bolts and handle assembly to remove any Teflon material sheared off during the installation process. Re-install the handle assembly (11) onto the housing (2) using four hex-head bolts.
5. Install air seal adapter (7) on piston rod assembly (3). Install spring pin (26) if present.
6. Install threaded adapter (8) or chuck assembly.
7. Reassemble barrel (4) to housing (2).
8. Install end cap (9) and tighten lockring (10).
9. Select appropriate mandrel/nosecap combination and install.

This page intentionally left blank for two-sided printing.

SECTION 5.0: TROUBLESHOOTING

This section provides solutions to some basic trouble spots. If you cannot solve your operational problems with the information provided in this section, please contact your nearest FTI representative.

NOTE: Should difficulties originate in the PowerPak, consult the specific PowerPak Operations, Maintenance and Repair Manual. Remember, always disconnect the PowerPak main air supply before performing any repair or maintenance.

PROBLEM	CAUSE	SOLUTION
1. PowerPak will not build full hydraulic pressure.	<ul style="list-style-type: none"> (a) The hydraulic pressure valve has not been properly adjusted. (b) One or more of the key air or hydraulic lines has not been securely connected. 	<ul style="list-style-type: none"> (a) Refer to Problem 4 for resolution. (b) Check the following hose connections: <ul style="list-style-type: none"> (1) Main air line quick disconnect fitting from shop air system to PowerPak. (2) Hydraulic quick couplings connecting the hoses to the PowerPak manifold and the puller to the hydraulic hoses. (3) Two male/female air line quick disconnect fittings connecting the puller to the PowerPak manifold.
	<ul style="list-style-type: none"> (c) Inadequate external pressure. 	<ul style="list-style-type: none"> (c) On FT-200, adjust external pressure regulator.
	<ul style="list-style-type: none"> (d) Inadequate air pressure. 	<ul style="list-style-type: none"> (d) Check the main air supply has not been interrupted and meets minimum flow requirements (90 psi (.621MPa), 50 cfm (1.42m³/min)).

CAUTION: Hydraulic oil under extreme pressure may cause serious injuries if not handled carefully. For technical assistance, please contact FTI's Technical Sales Department.

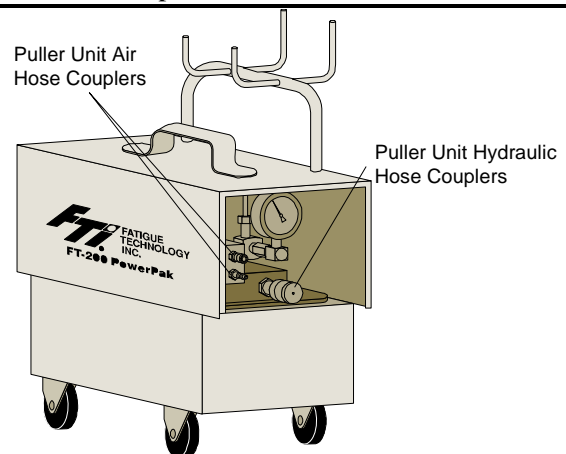
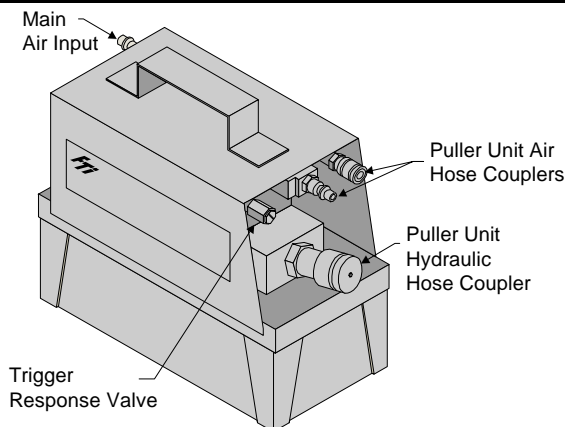

PROBLEM

CAUSE

SOLUTION

2. Puller retracts on first trigger actuation but will not return to start position. The hydraulic hose is difficult to bend or coil (indicating unrelieved pressure built up in the hose).

- (a) The hydraulic quick coupler line has not been completely tightened at the PowerPak manifold (there should be no space between the PowerPak coupler and the hose fitting flange).

- (a) Once hydraulic pressure has been introduced to the hydraulic hose, the pressure must be relieved before the coupler can be sufficiently tightened.

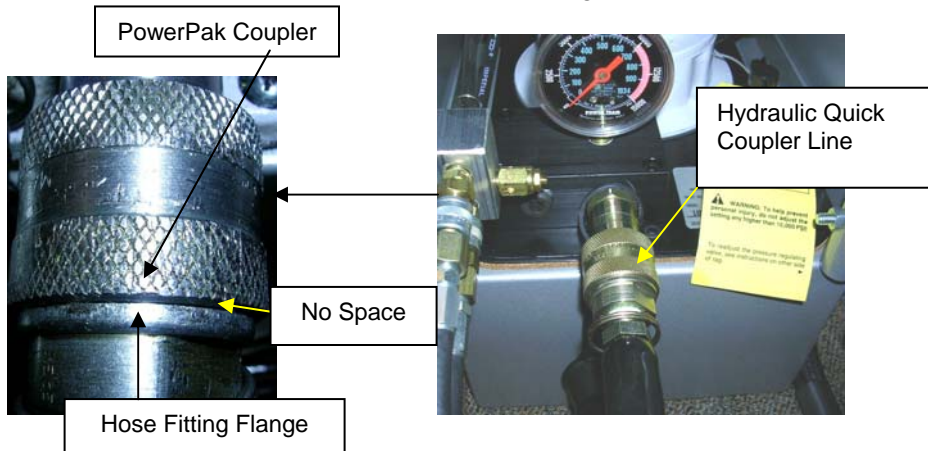

Procedure for relieving hydraulic pressure:

- (1) Disconnect main air supply.
- (2) Disconnect coupler from PowerPak.
- (3) Wrap the fitting with a rag to absorb the squirting oil and slowly turn the coupler off the hydraulic hose to allow hydraulic oil to bleed out.
- (4) Once pressure is relieved, coupler may be tightened and reinstalled onto PowerPak.
- (5) Reattach air lines to get puller to return.

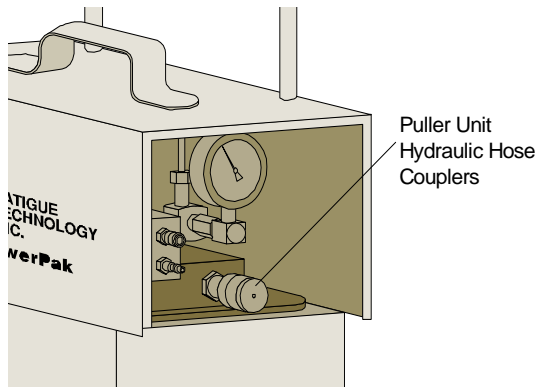

3. PowerPak will not generate constant pressure (or hiccups).

- (a) Trigger response valve requires adjustment.

- (a) Adjustment procedure:

- (1) Loosen locknut on trigger response valve.
- (2) Using a screwdriver, open screw counterclockwise until PowerPak will not start when puller trigger is depressed.

*** (For pullers with a cartridge trigger assembly (see Section 6.2), the trigger response valve should be closed) ***

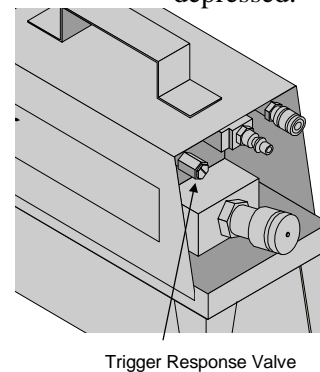
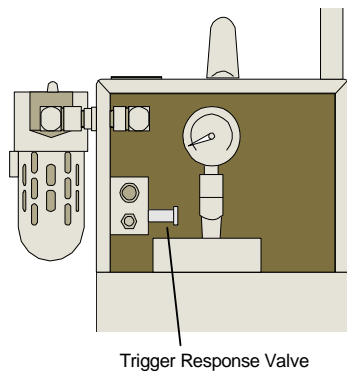

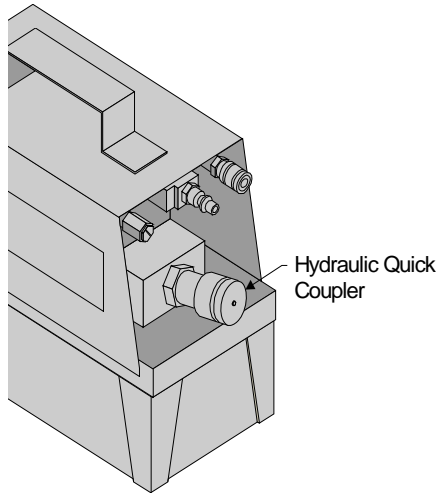
PROBLEM**CAUSE****SOLUTION**

- | | | |
|---------------------------------------------------------------------------------------------|-------------------------------------------------------------------------------------------------------------------|------------------------------------------------------------------------------------------------------------------------------------------------------------------------------------------------------------------------------------------------------------------------------------------------------------------------------------------------------------------------------------------------------------------------------------------------------------------------------|
| <p>4. PowerPak will not operate or maintain sufficient pressure (6,000 psi (41.37MPa).)</p> | <p>(b) Check main air flow for 90 psi (.621MPa), 50cfm (1.42m³/min).</p> | <p>(3) Turn screw clockwise until:</p> <ul style="list-style-type: none"> - PowerPak generates constant pressure when puller trigger is depressed, and - PowerPak starts instantly when puller trigger is depressed and stops instantly when released. When the puller trigger is depressed, the PowerPak should be run at the pre-set pressure until the trigger is released. <p>(4) Hold set screw in position and tighten locknut until snug.</p> |
| | <p>(a) Hydraulic pressure requires adjusting (applicable to FTI-200 PowerPak only).</p> | <p>(a) Adjust PowerPak pressure valve:</p> <ol style="list-style-type: none"> (1) Squeeze trigger on puller unit to activate PowerPak. (2) If pressure does not reach 6,000 psi (41.37MPa), loosen lock and turn hydraulic pressure control clockwise until pressure reaches 6,000 psi (41.37MPa). (3) Tighten locknut to secure available shop air. |
| <p>5. Threaded adapter/chuck assembly will not unthread from piston assembly</p> | <p>(a) Torque required to unthread threaded adapter/chuck assembly is high enough to spin the piston assembly</p> | <p>(a) See disassembly procedures in Section 4.4-6 (use flats on back of threaded adapter and mating air seal adapter).</p> |

PROBLEM**CAUSE****SOLUTION**

(b) Inadequate air supply.

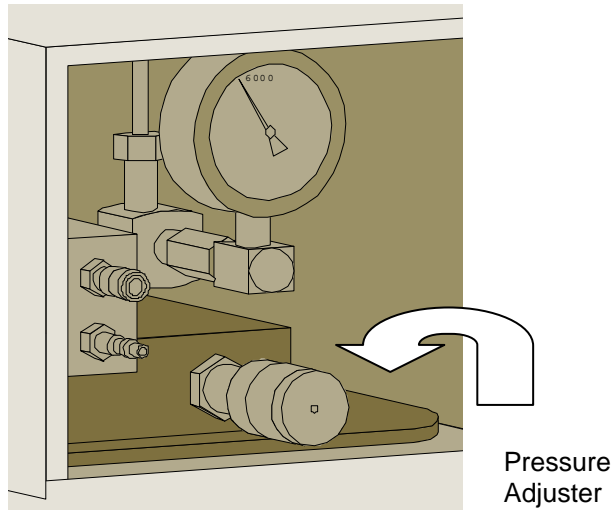

(b) Increase pressure or flow of available shop air.
 -If PowerPak will not generate or maintain sufficient pressure, the main air line pressure is too low or the PowerPak hydraulic pressure requires adjustment.
 -Air pressure requirements:
 1/2-inch (12.7mm) ID air line with 90 to 120 psi (.621 to .827MPa) for the FT-200.
 3/8-inch (9.525mm) ID air line with 90 to 120 psi (.621 to .827MPa) for the FT-20.
 -Flow requirements:
 40-50 cfm (1.13-1.42m³/min) for the FT-200.
 20 cfm (.57m³/min) for the FT-20.

5. The mandrel sticks in the hole when the puller is activated.

(a) Not enough pressure used to generate pull forces.

(a) Use the following procedure to analyze the problem.

- (1) Actuate the puller and observe pressure reading on PowerPak pressure gage (FT-200 PowerPak only).
- (2) Pressure gage should read 6,000 psi (41.37MPa). (Note: FT-20 PowerPak is factory set at 10,000 psi (68.95MPa).) If any increase in pressure is required, refer to the solution for Problem 4 in this section for instructions.
- (3) Actuate puller again. If mandrel remains stuck, increase pressure to 10,000 psi (68.95 MPa).
- (4) If mandrel remains stuck at 10,000 psi (68.95MPa), disengage the mandrel from the puller. Push the mandrel out. Contact FTI's Technical Sales Department for additional assistance.

SECTION 6.0: ILLUSTRATED PARTS BREAKDOWN

Fatigue Technology has redesigned the trigger assembly for Little Brute Series Puller Units. All Little Brute Puller Units with serial numbers equal to or greater than the serial numbers in Table 6.0-1 have the new cartridge trigger assembly. The new design will reduce the occurrence of trigger air leaks, perform more reliably (better pump actuation), and be easier to maintain. The previous trigger design detailed in Section 6.3 can be easily replaced with this improved trigger assembly detailed in Section 6.1, which is the Cartridge Trigger Assembly Kit (FTI-CT-RK) or the Little Brute Rework Kit (LB-CT-RK) and the Puller Trigger Rework Tool Kit (FTI-CT-RKT). One FTI-CT-RK or LB-CT-RK kit is required for each puller converted. Only one FTI-CT-RKT is required regardless of the number of pullers converted. The FTI-CT-RKT kit also includes detailed instructions on how to perform the modification.

**Table 6.0-1
Trigger Assembly Conversion**

FTI Model Number	FTI Part Numbers	FTI Serial Number
LB-10	2327-001, 2885-001, 2305-001, 2305-013, 2885-013, 2305-007, 2307-020, 2885-007	0707
LB-15	2305-002, 2305-008, 2885-014, 2885-002, 2885-019, 2305-019, 2305-014, 2885-008	FTI-424
LB-20	2885-015, 2885-003, 2885-009, 2305-009, 2305-003, 2305-021, 2305-015	3109
LB-25	2885-010, 2885-016, 2305-004, 2305-010, 2305-016, 2885-004	0424
LB-30	2305-022, 2305-017, 2885-017, 2305-011, 2305-005, 2885-011, 2885-005	0713
LB-35	2885-006, 2305-018, 2885-018, 2305-012, 2305-006, 2305-023, 2885-012	2057
LB-20-AT	2785-003	1091
LB-30-AT	2785-005	0508
LB-35-AT	2785-006	0427

6.1 LITTLE BRUTE REWORK KIT; PARTS LIST AND DIAGRAM

All Little Brute Puller Units with serial numbers equal to or higher than the serial numbers in Table 6.0-1 have a cartridge trigger assembly as shown in Figure 6.1-1. This trigger configuration can be readily identified by the brass pushbutton (the previous trigger assembly is identified by an aluminum pushbutton - see Section 6.3).

A diagram of the Little Brute Puller Unit is shown in Figure 6.1-1, with parts for the Rework Kit corresponding to the following table:

**Table 6.1-1
Parts List for Little Brute Rework Kit (LB-CT-RK)**

Piece Number	Quantity	Description	Part Number
1	1	Adapter, LB Air Seal (seal and fitting)	2339-001
2	4	Screw, SHC (8-32UNCX 3/8)	1026-002
3	1	Pushbutton, Brass	1187-623
4	1	Retaining Ring, Internal	1187-624
5	1	Sleeve, Puller Handle Trigger	3196-001
6	1	Adapter, LB Hydraulic	2039-001
See Section 6.2	1	Kit, LB Seal (LB-SK)	8000-484

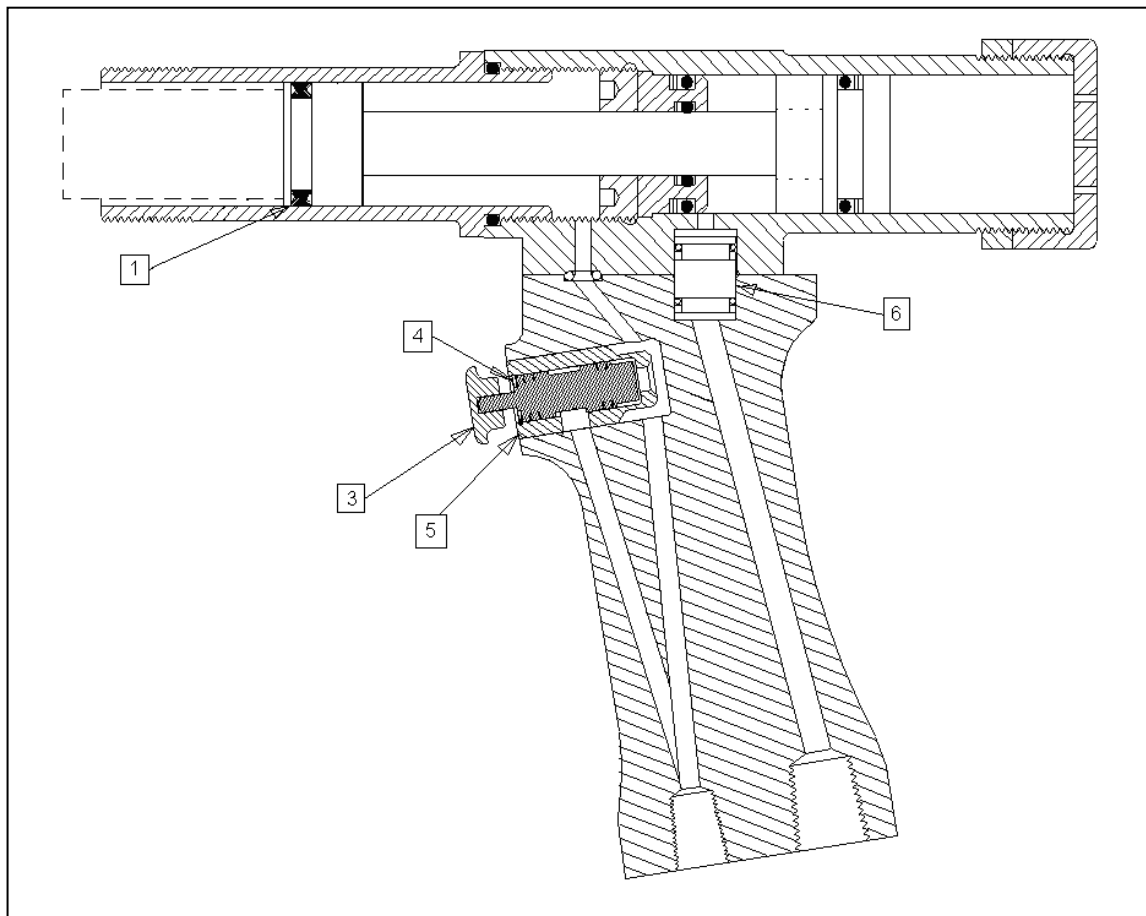

**Figure 6.1-1
Diagram of Little Brute Rework Kit Parts (LB-CT-RK)**

6.2 LITTLE BRUTE SEAL KIT; PARTS LIST AND DIAGRAM

All Little Brute Puller Units with serial numbers less than the serial numbers on Table 6.0-1 will use Piece Number 2 to replace the seal in the trigger assembly (see Section 6.3). A diagram of the Little Brute Puller Unit is shown in Figure 6.2-1, with parts for the seal kit corresponding to the following table:

Table 6.2-1
Little Brute Seal Kit (LB-SK)

Piece Number	Description	Part Number	Quantity
1	Valve, Cartridge Trigger	1187-622	1
See Section 6.3, pc. 2	Seal, LB Handle	2040-001	1
2	Ring, Backup	1046-044	2
3	O-Ring	1046-045	2
4	O-Ring	1046-012	1
5	O-Ring	1046-016	1
6	O-Ring	1046-002	2
7	Ring, Backup	1046-003	2
8	O-Ring	1046-014	1
9	Ring, Backup	1046-015	1
10	Seal, Omni	1046-017	1
11	O-Ring	1046-112	1

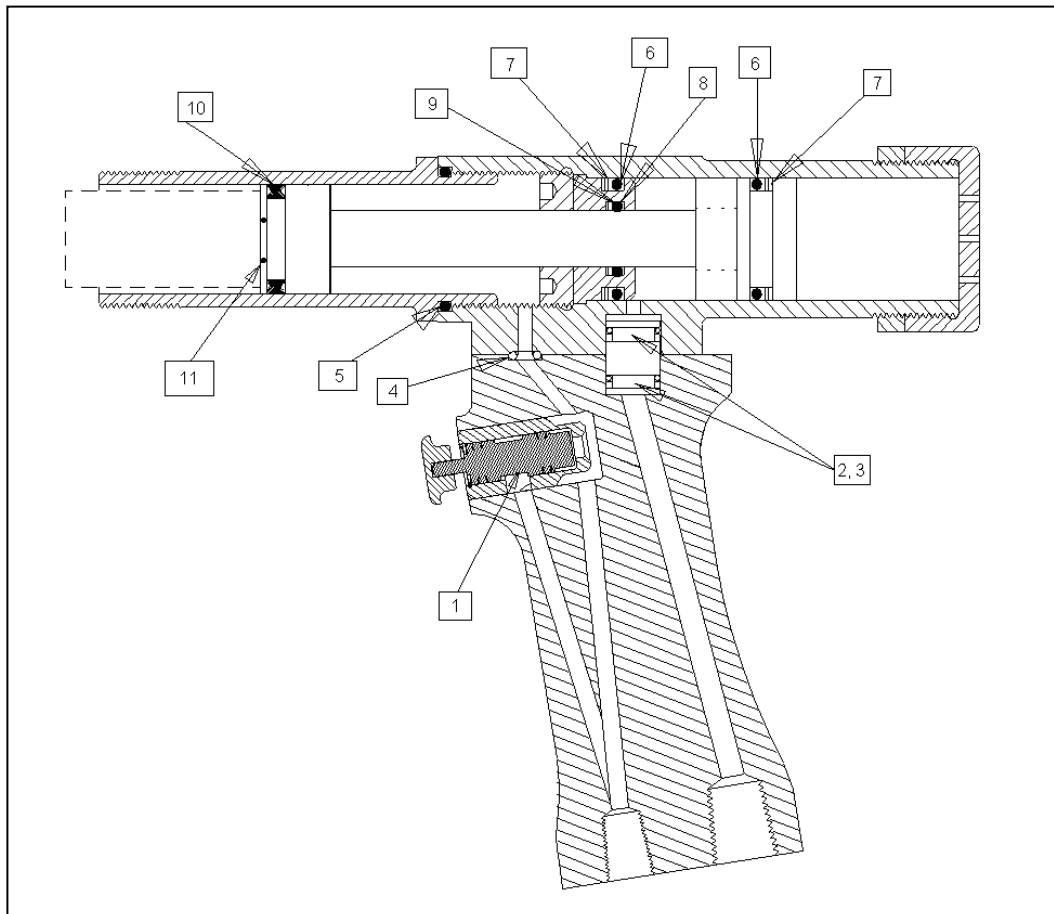

Figure 6.2-1
Diagram of Little Brute Assembly (LB-SK)

6.3 PREVIOUS LITTLE BRUTE TRIGGER ASSEMBLY; PARTS LIST AND DIAGRAM

All pullers with serial numbers previous to those listed in Table 6.0-1 have the trigger assembly detailed below. These trigger assemblies can be readily identified by the aluminum pushbutton. (The new trigger assemblies have a brass pushbutton). These trigger assemblies can be reworked by ordering the Cartridge Trigger Assembly Kit (FTI-CT-RK) or the Little Brute Rework Kit (LB-CT-RK), and the Puller Trigger Rework Tool Kit (FTI-CT-RKT) in Section 6.1. A diagram of the Little Brute Puller Unit is shown in Figure 6.3-1, with parts for the previous trigger assembly corresponding to the following table:

**Table 6.3-1
Previous Little Brute Trigger Assembly**

Piece Number	Quantity	Description	Part Number
1	1	Sleeve, LB Handle	2044-001
2	1	Seal, LB Handle	2040-001
3	1	Retainer, LB Handle	2043-001
4	1	Trigger, LB Handle	2042-001
5	1	Spring, LB Handle	1005-003
6	1	Ball, .250 Dia. Stl.	1045-025
7	1	Pin, 1/8 x 3/4 Std. Spring	1045-026

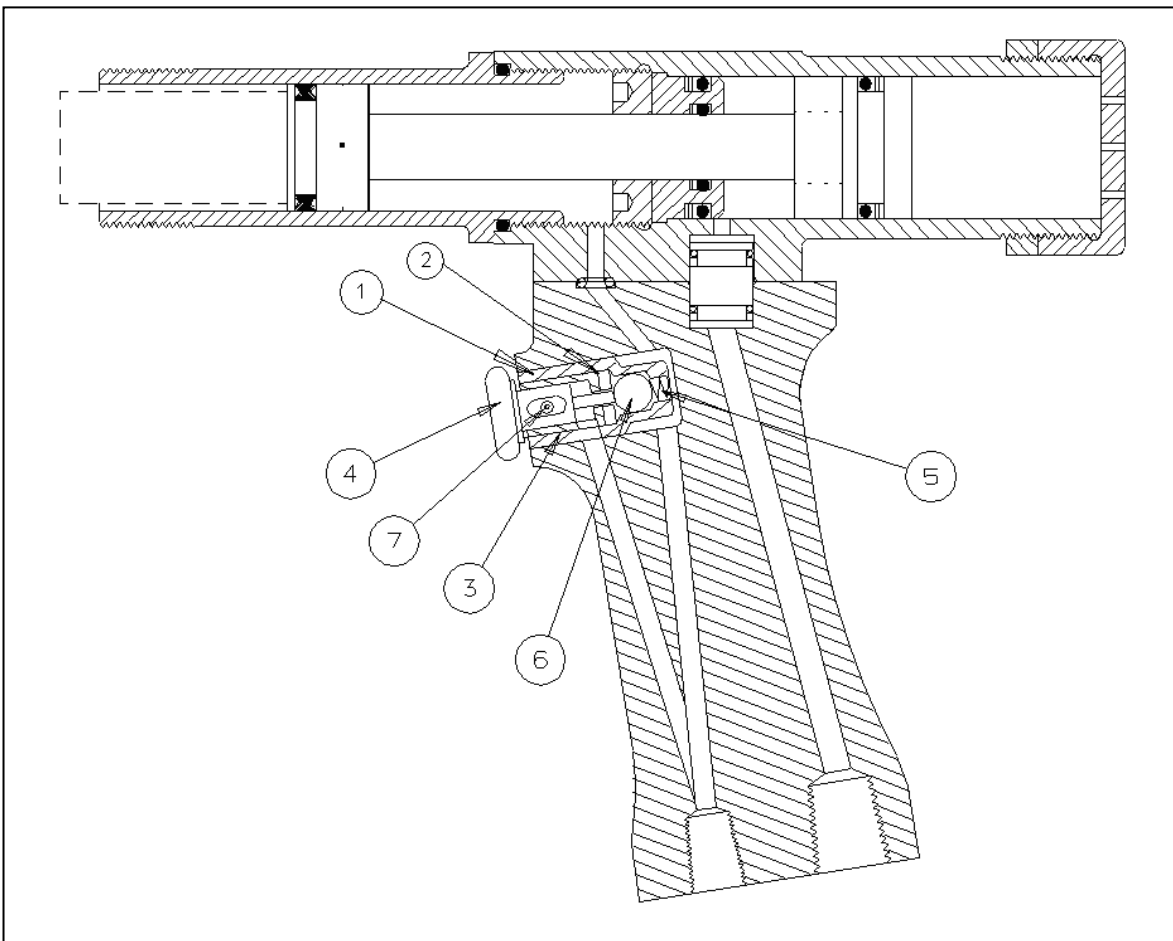

**Figure 6.3-1
Diagram of Previous Little Brute Trigger Assembly**

6.4 LITTLE BRUTE PULLER ASSEMBLY; PARTS LIST AND DIAGRAM

A diagram of the Little Brute Puller Unit is shown in Figure 6.4-1, which corresponds to the parts list on the following page.

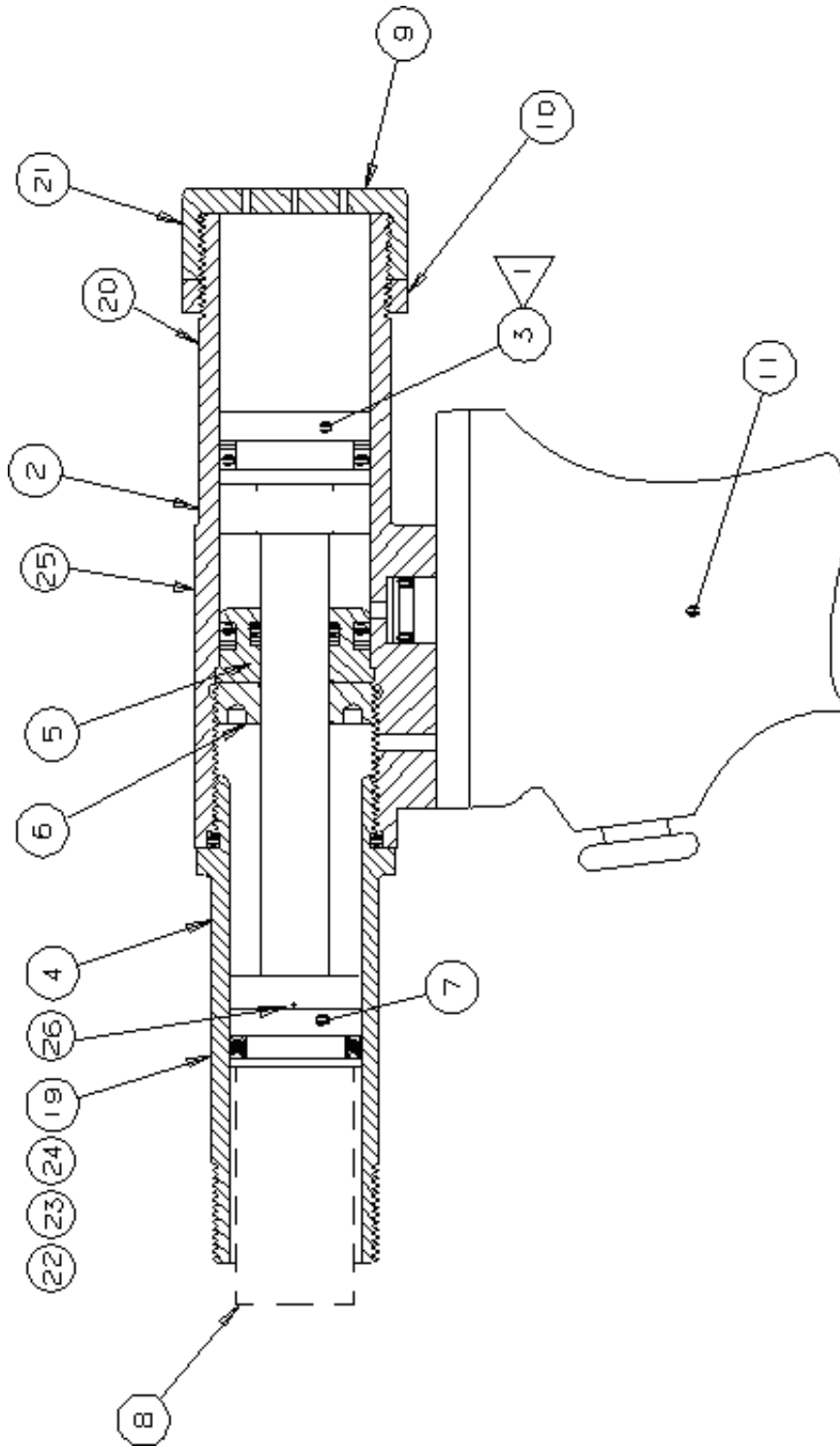

Figure 6.4-1
Little Brute Assembly

The following parts list corresponds to the drawing in Figure 6.4-1 on the previous page.

**Table 6.4-1
Little Brute Parts List**

Reference #	Description	Part Number	Reference Information
2	LB Housing	2333-00*	LB-**-D2
3	LB Piston Assembly	2334-00*	LB-**-D3
4	LB Barrel	2335-00*	LB-**-D4
5	LB Sleeve	2337-001	LB-D7
6	LB Sleeve Retainer	2338-001	LB-D8
7	LB Air Seal Adapter	2339-001	LB-D9
8	LB Threaded Adapter ⁽¹⁾	2340-001	LB-D10
9	End Cap	2136-001	LB-D5
10	Lockring	2120-003	LB-D6
11	Handle Assembly	2049-001	LB-H-1 ⁽³⁾
19	“Warning” Label	1009-185	None
20	“FTI” Label	1009-094	None
21	“Do Not Strike” Label	1009-184	None
22	Read Manual Label	1187-107	None
23	Eye Protection Label	1187-106	None
24	Ear Protection Label	1187-105	None
25	CE Label	1166-001	None
26	Roll Pin ⁽²⁾	1187-093	None

* Indicates part numbers dependent on Little Brute model number (-10, -20, -25, etc.).
Contact FTI Technical Sales for assistance.

- (1) Chuck assemblies may be substituted for tang-style or pintail mandrels. Contact FTI for assistance.
- (2) Contained as part of the Air Seal Adapter, part number 2339-001.
- (3) All new Little Brute handles are equipped with new cartridge trigger assembly (see Section 6.1).