

---

**FTI OPERATIONS, MAINTENANCE AND REPAIR MANUAL**

**Jumbo Brute (JB-60)  
Cylinder Puller Unit**

**FTI Part #2720-062**

**Revised January 2006**



Fatigue Technology Inc. (FTI) is the supplier of Split Sleeve Cold Expansion™ (Cx™) systems to the aerospace industry worldwide. These proprietary systems and associated tooling may be covered by patents or agreements owned by, or exclusively licensed to Fatigue Technology Inc. Use of tooling procured from other than a licensed source may constitute patent infringement.

The detailed tooling information in this manual was compiled and written by FTI. The tooling was designed specifically for use with FTI's Cx Systems. FTI cannot be held responsible for damage or injury as a result of operating this equipment if it is used for other than the process intended, with any other tooling not provided by FTI, or not used in accordance with the instructions contained in this manual. To avoid personal injury, please observe all safety precautions and instructions. FTI reserves the right to change specifications or configurations of equipment detailed in this manual as part of our ongoing technical and product improvement programs. If you have any questions about the use or serviceability of this equipment, please contact our Technical Sales Department.

FTI's systems and processes are the subject matter of one or more of the following patents: 4,809,420; 4,885,829; 4,934,170; 5,083,363; 5,096,349; 5,103,548; 5,127,254; 5,218,854; 5,245,743; 5,305,627; 5,341,559; 5,380,136; 5,405,228; 5,433,100; 5,468,104; 6,077,010; 6,183,180; 6,487,767; 6,792,657; 5,129,253; 513,898; 692015124; 581,385; 69310828; 468,598; 69105390; 643,231; 69414946; 696,686; 785,366; and other patents pending. These systems and processes are tooling critical and must be performed in accordance with FTI's specifications or controlling documents. To ensure proper results from FTI's cold expansion systems and to be licensed to use FTI's patented processes, it is essential that FTI's complete integrated system of tooling be purchased and utilized. The use of tooling purchased from other than a licensed supplier could jeopardize fatigue life enhancement and may constitute patent infringement.

**Uncontrolled if Printed**

## ABOUT FATIGUE TECHNOLOGY

---

Fatigue Technology Inc. (FTI) has provided innovative solutions to fatigue problems in metal structures since 1969. Complete systems of tooling are used worldwide to enhance the fatigue life of holes in airframes, turbine engines, and other critical structures.

The FTI staff of professionals provides a full range of support services including:

- Application engineering
- Detailed project planning, implementation and management
- On-site assistance, including training and tool room setup

Complete inventory allows FTI to respond quickly to customers' requirements.

The Technical Sales Department is always available to assist with special fatigue enhancement requirements. Please contact FTI with questions at any time.



Burke F. Gibson  
CEO/Chairman of the Board

This page intentionally left blank for two-sided printing.

## TABLE OF CONTENTS

<b>SECTION</b>	<b>DESCRIPTION</b>	<b>PAGE</b>
Section 1	Introduction.....	1
1.1	About the Jumbo Brute (JB-60) Cylinder Puller Unit.....	1
1.2	General Description.....	1
1.3	General Specifications.....	2
Section 2	Safety.....	5
Section 3	Puller Unit Operating Instructions.....	7
3.1	Puller Unit Setup Procedure and Operation.....	7
3.2	Activation of Puller Unit.....	8
3.3	PowerPak Pressure Adjustment.....	8
Section 4	Puller Unit Maintenance.....	9
4.1	General Cleaning.....	9
4.2	Lubrication.....	9
4.3	Inspection.....	9
4.4	Disassembly.....	9
Section 5	Troubleshooting.....	11
Section 6	Illustrated Parts Breakdown.....	15
6.1	JB-60 Puller Unit Diagram.....	15
6.2	JB-60 Puller Unit Assembly Parts List.....	16
6.3	JB-60 Remote Trigger Assembly; Parts List.....	17

### FIGURES

Figure 1.3-1	JB-60 Parts.....	2
Figure 1.3-2	JB-60 Dimensions.....	3
Figure 6.1-1	JB-60 Diagram.....	15
Figure 6.3.1-1	Diagram of Remote Trigger Assembly.....	17
Figure 6.3.2-1	Diagram of Previous Trigger Assembly.....	18

### TABLES

Table 1.3-1	JB-60 Specifications.....	3
Table 6.2-1	JB-60 Parts List.....	16
Table 6.3.1-1	Parts List for Cartridge Trigger Assembly Kit (FTI-CT-RK).....	17
Table 6.3.2-1	Parts List for Previous Trigger Assembly.....	18

This page intentionally left blank for two-sided printing.

## SECTION 1: INTRODUCTION

---

This instruction manual contains information on the operation and maintenance of the Jumbo Brute (JB-60) Cylinder Puller Unit. To obtain optimum performance and many years of trouble free service, operate the puller unit properly and carefully follow maintenance procedures.

Read this manual before operating the puller unit and retain it for future reference.

### ***1.1 ABOUT THE JUMBO BRUTE (JB-60) CYLINDER PULLER UNIT***

The JB-60 Puller Unit is a powerful, heavy-duty tool specifically designed for use with all Fatigue Technology Inc. (FTI) Cold Expansion (CX™) processes. The JB-60 Puller is designed to pull a mandrel through a hole with the pre-lubricated stainless steel split sleeves used in this process, or pre-lubricated bushing used in the ForceMate® (FmCX™) process.

The JB-60 Puller has a maximum pull force of 60,000 pounds (266.89kN) at 10,000 psi (68.95MPa) pump pressure. The JB-60 is available for cold expanding holes over 1-1/2 inch (38mm) in diameter in aluminum, steel, and titanium. Please contact FTI technical support staff for application assistance.

The JB-60 will accommodate tooling for stack-up of approximately five inches (125mm).

The JB-60 has a fail-safe air control system that causes the puller retraction cycle to be interrupted whenever the operator releases finger pressure on the trigger or in the event of air or hydraulic hose failure. The puller unit operates in conjunction with FTI's FT-200 PowerPak air-hydraulic power units. (The portable FT-20 PowerPak is not recommended.)

### ***1.2 GENERAL DESCRIPTION***

Hydraulic Fluid Requirements.....	U.S. MIL-H-5606
Operating Hydraulic Pressure.....	10,000 psi (68.95MPa)
Pull Force Capacity.....	60,000 pounds (266.89kN)
PowerPak Air Line Requirements .....	3/8 inch to 1/2 inch (9.5 to 12.7mm) inside diameter
PowerPak Air Flow Requirements.....	90 to 120 psi (0.62 to 0.82MPa), 50 cfm (1.42m <sup>3</sup> /min)
Actuation.....	Pneumatic
Operation .....	Hydraulic
Compatible PowerPak.....	FT-200
Fail-Safe.....	Air logic safety circuit halts mandrel retraction when trigger is released

### 1.3 GENERAL SPECIFICATIONS

The JB-60 Puller is designed for applications where the capacity of the Big Brute Puller Unit is exceeded.

**Tooling Selection:** The mandrels and nosecaps used with the JB-60 Puller are designed to the specific needs of the customer and application requirements. Please contact FTI technical support staff for application assistance.

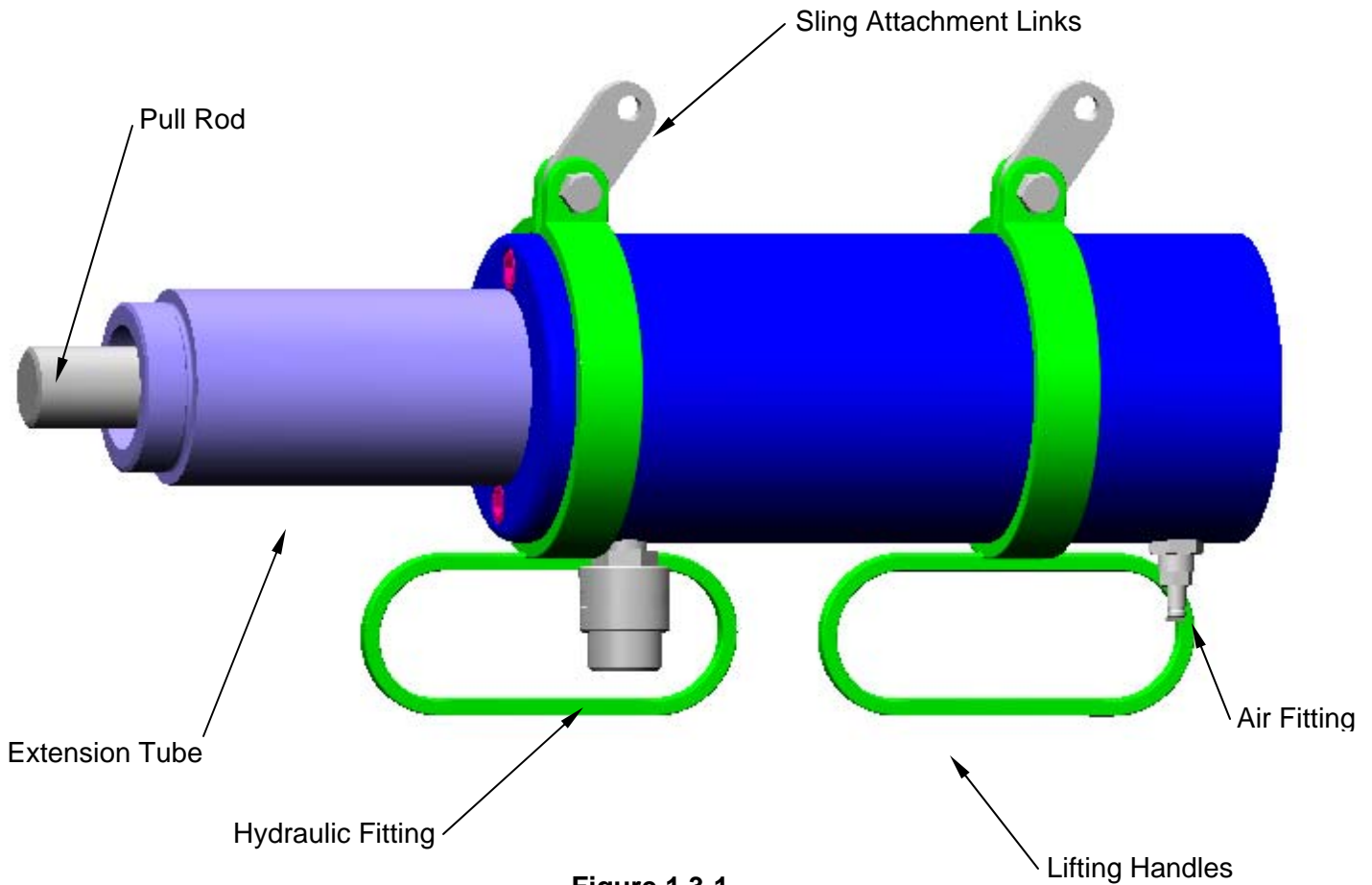
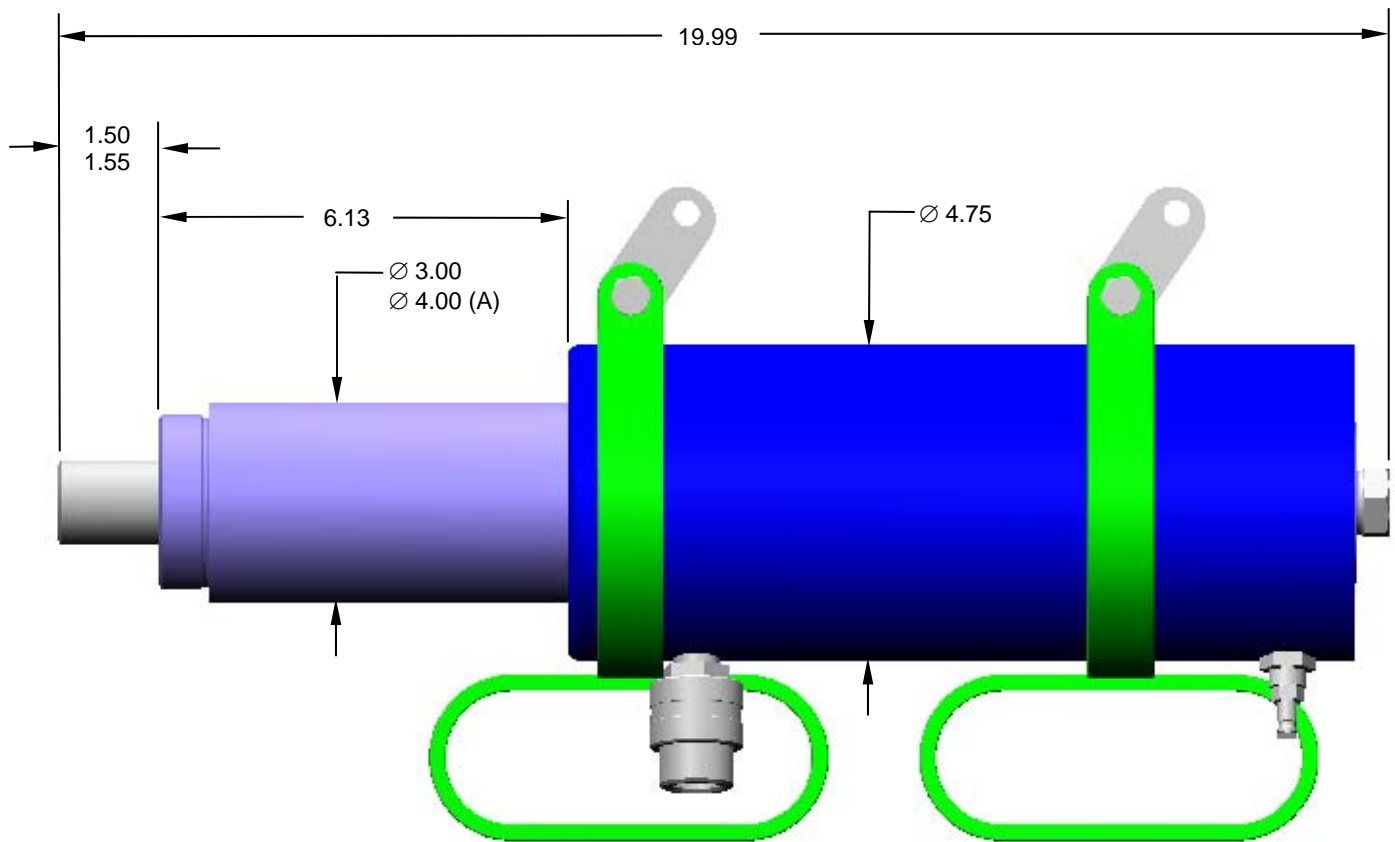

**Figure 1.3-1  
JB-60 Parts**

**Table 1.3-1  
JB-60 Specifications**

Model Number	Maximum Material Stackup (inch)	Length (inch)	Stroke (inch)	Weight <sup>1</sup> (lb.)	Shipping Weight (lb.)
JB-60	≈ 5 (125mm)	19.99 (508mm)	6.0 (152mm)	64 (29 kg)	108 (49 kg)
JB-60A	≈ 5 (125mm)	19.99 (508mm)	6.0 (152mm)	66 (30 kg)	110 (50 kg)

Note 1: Puller only, does not include hoses or tooling.



**Figure 1.3-2  
JB-60 Dimensions**

This page intentionally left blank for two-sided printing.

## SECTION 2: SAFETY

---

When used in accordance with these instructions, the puller unit is safe and easy to use. All general safety precautions associated with hydraulic and pneumatically operated power tools should be observed. Many of these are noted in this section.

The JB-60 Puller Unit is not intended for hand-held operation. The strap handles are provided to carry or to maneuver the puller into position. The sling attachment links are provided for ease of attachment to the operator's hoist apparatus. A sling made from chain, cable or strap with minimum load capacity certification is highly recommended. **DO NOT** use rope or other materials not intended for material handling.

Ultimately, operators are responsible for their own safety; however, the following general safety precautions should be observed.

1. Wear eye protection when operating the puller unit.
2. Disconnect the air supply when:
  - Maintenance is to be performed.
  - Hydraulic hose is disconnected.
  - PowerPak is not in use.
3. In the event of a ruptured or leaking hydraulic hose, **IMMEDIATELY RELEASE THE TRIGGER AND DISCONNECT THE AIR LINE**, at the air coupler, from the PowerPak (see figure at right). Never use your hands to grasp a leaking hose under pressure. The force of escaping hydraulic fluid could cause serious injury.
4. **DO NOT** attempt to disconnect the hydraulic hose while it is under pressure.
5. **DO NOT** expose hoses to potential hazards such as extreme heat or cold, sharp surfaces or heavy impact.
6. **DO NOT** allow hoses to kink, twist, curl or bend so tightly that the oil flow within the hose is blocked or reduced. Periodically inspect the hose for wear or damage that could cause premature failure of the hose and possibly result in injury. Damaged hoses must be replaced immediately.
7. **DO NOT** use the hose to move attached equipment.
8. Hose material and coupler seals must be compatible with hydraulic fluid that meets the requirements of U.S. MIL-H-5606.
9. Hoses must not come in contact with toxic materials such as creosote-impregnated objects and some paints. Keep couplers and hoses clean and free of paint. Hose deterioration due to chemical degradation may cause the hose to fail under pressure. Damaged hoses must be replaced immediately.
10. Release puller unit trigger when mandrel clears the work piece or becomes stuck.
11. Before operating pump, make sure all hose connections are tightened securely. **DO NOT** over tighten.
12. Keep hands away from nosecap assembly while holding nosecap against the workpiece.

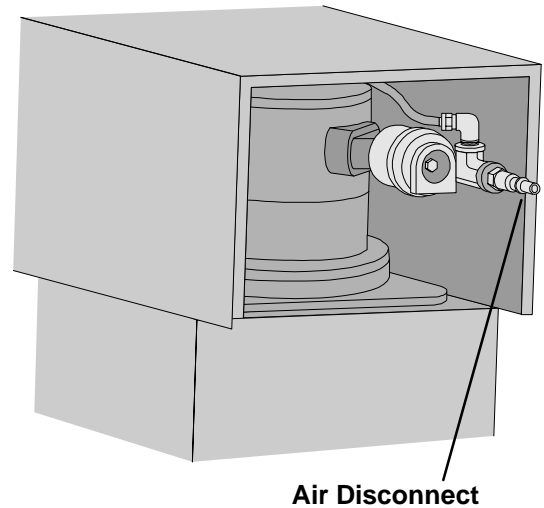

13. Hose strain relievers must be placed around hose fittings during use. Damaged strain relievers must be replaced immediately.
14. Before operating the pump, tighten all hose connections using the proper tools. Do not over-tighten the connections. Connections need only be tightened securely and leak-free. Over-tightening may cause premature thread failure or high-pressure fittings to split at pressures lower than their rated capacities.
15. Inspect hydraulic hose for signs of wear (cuts, abrasions or kinks) to the outer shell material. Pump clean oil through the entire length. Pressurize the hose and check for leaks at the crimped connectors, between the hose material and the fitting and between the fitting and the coupler.

**CAUTION:** Operators must read this manual in its entirety before using the JB-60 Puller Unit. Eye and ear protection must be worn during operation.

## SECTION 3: PULLER UNIT OPERATING INSTRUCTIONS

---

Become familiar with these instructions before operating the puller.

Check to assure a sufficient working envelope for unobstructed operation. Note that during puller operation the backside of the puller (hex end) will extend up to the maximum stroke limit.

### 3.1 PULLER UNIT SETUP PROCEDURE AND OPERATION

Refer to Section 6 (Illustrated Parts Breakdown) for parts identification.

1. Inspect all threads and fittings for signs of wear or damage and replace them if necessary.
2. Remove the protection sleeve on the pull rod and inspect the threads.
3. Test shop air to ensure that air is clean, dry, and between 90 and 120 psi (0.62 and 0.82MPa) at 50 cfm (1.42m<sup>3</sup>/min).
4. Uncoil the air-hydraulic extension hose assembly and inspect all threads, couplings and hoses for damage and degradation. Any damaged component must be replaced immediately.
5. Remove thread protectors from the hydraulic fittings and thread the hydraulic hose fitting from the hose assembly (male) onto the hydraulic fitting of the puller unit. Wipe fittings clean prior to connecting. Make sure to thread couplers completely together. There should be positive contact between the coupler and the hose-fitting flange (you should not be able to insert a piece of paper between the coupler and the hose fitting flange—see Section 5, Problem 2 for more information). Failure to completely tighten the coupler will prevent the puller from returning to the forward (start) position. Strain relievers must be placed on hose fittings during operation. If strain relievers are worn or damaged, they must be replaced immediately.
6. Connect the female air quick disconnect onto the male fitting of the puller unit.
7. Remove thread protectors from the hydraulic fittings and thread the hydraulic hose fitting from the hose assembly (male) onto the hydraulic fitting of the FTI PowerPak (female). Wipe fittings clean prior to connecting. Make sure to thread couplers completely together. Failure to do so will prevent the puller from returning to the forward (start) position. Strain relievers must be placed on hose fittings during operation. If strain relievers are worn or damaged, they must be replaced immediately.
8. Connect the male air quick disconnect attached to the T-fitting into the female coupler of the FTI PowerPak.

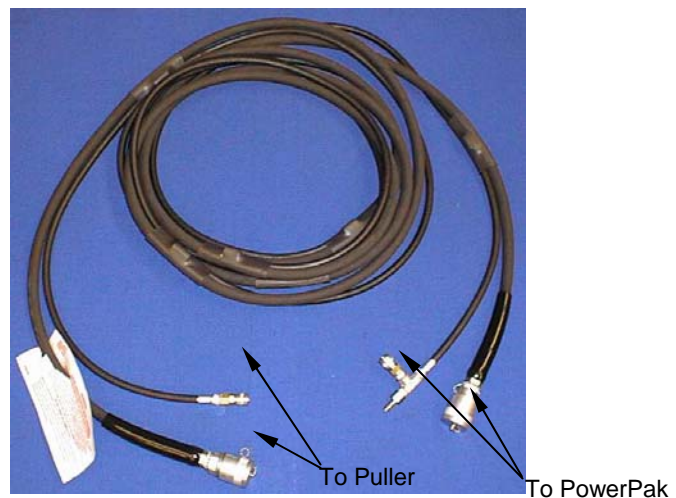

9. Uncoil the trigger assembly and inspect all threads, couplings and hoses for damage and degradation. Any damaged component must be replaced immediately.
10. Connect the female air quick disconnect of the trigger assembly hose to the male fitting of the FTI PowerPak.
11. Connect the male air quick disconnect into the female coupler at the T-fitting of the air-hydraulic extension hose assembly.
12. Connect the female quick disconnect of a 1/2-inch (12.7mm) ID shop air line onto the male air inlet of the PowerPak.

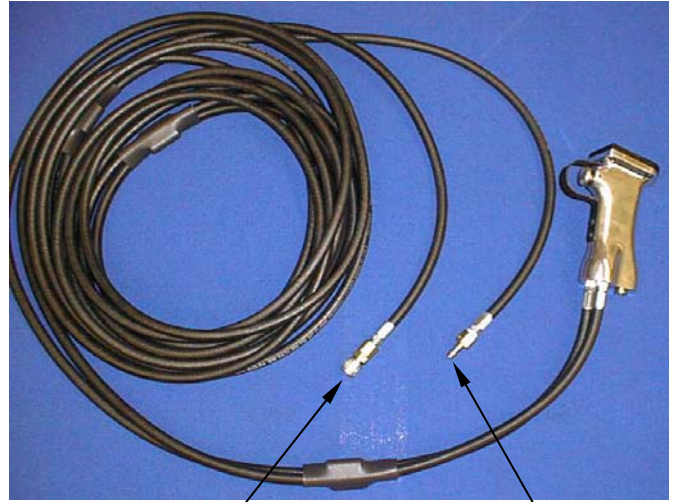

### 3.2 *ACTIVATION OF PULLER UNIT*

1. The puller can be activated only when connected to the FTI PowerPak.
2. Activate puller by depressing the trigger on the handle. Hydraulic pressure is transmitted through the hose to the cylinder of the puller, which then retracts the hydraulic piston that performs the cold expansion procedure.
3. Releasing the trigger changes pressure at the pilot valve and stops the pull cycle. Air pressure returns the puller to original position.
4. If the puller fails to operate as detailed above, refer to Section 5 (Troubleshooting).

### 3.3 *POWERPAK PRESSURE ADJUSTMENT*

1. Activate the puller as described above. Hold the trigger until the PowerPak attains peak pressure and release the trigger two seconds after the peak pressure is reached.
2. If the pressure does not reach 10,000 psi (68.95 MPa), adjust the PowerPak pressure relief valve:
  - a. Squeeze the trigger to activate the puller unit.
  - b. Loosen the locknut and turn the hydraulic pressure valve clockwise until the pressure reaches 10,000 psi (68.95 MPa).
  - c. Tighten the locknut to secure.

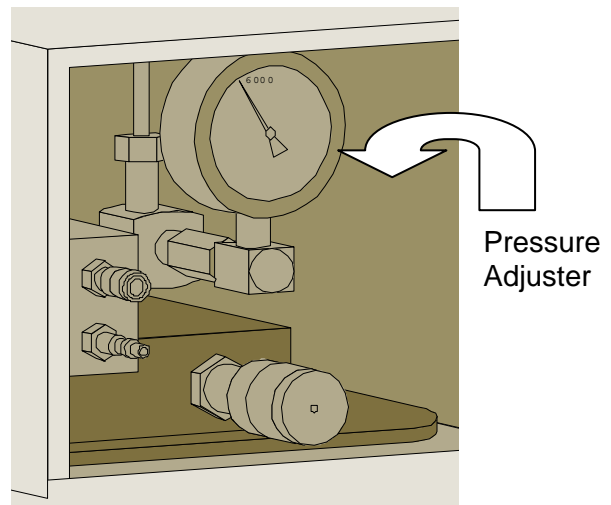

## **SECTION 4: PULLER UNIT MAINTENANCE**

---

The puller requires routine checking and periodic preventative maintenance to ensure safe, trouble-free operation. No special maintenance is required. The following maintenance actions are suggested.

**CAUTION:** Before attempting any maintenance operations on the puller, disconnect the PowerPak from the air supply or disconnect the puller from the PowerPak or hand pump.

### **4.1 GENERAL CLEANING**

1. Periodically clean the outer surfaces of the puller unit and PowerPak.
2. When not in use, ensure thread protectors are re-installed on the hydraulic fittings and the pull rod.
3. Keep all hose connections free of dirt and grime. Doing so will dramatically extend the life of pumps and puller seals.

### **4.2 LUBRICATION**

1. There is no internal lubrication requirement for the puller unit.
2. Whenever the puller is to be stored for any length of time, maintain a thin coat of 10-weight oil on the outside of black oxide surfaces.

### **4.3 INSPECTION**

Periodically inspect threaded fittings, hoses, and strain relievers for cracks, leaks or other damage. Repair and replace immediately.

### **4.4 DISASSEMBLY**

The JB-60 Puller Unit is not intended for repair or disassembly in the field. In the event of hydraulic fluid leakage around the seals, the puller should be returned to FTI. Please contact FTI technical support staff for assistance.

This page intentionally left blank for two-sided printing.

## SECTION 5: TROUBLESHOOTING

This section provides solutions to some basic problems. If you cannot solve your operational problems with the information provided in this section, please contact your nearest FTI representative (see list inside back cover).

**NOTE:** Should difficulties originate in the PowerPak, consult the specific PowerPak Operations, Maintenance and Repair Manual. Remember, always disconnect the PowerPak main air supply before performing any repair or maintenance.

PROBLEM	CAUSE	SOLUTION
1. PowerPak will not build full hydraulic pressure.	(a) One or more of the key air or hydraulic lines has not been securely connected.	(a) Check the following hose connections: (1) Main air line quick disconnect fitting from shop air system to PowerPak. (2) Hydraulic quick couplings connecting the hoses to the PowerPak manifold and the puller to the hydraulic hoses. (3) Two male/female air line quick disconnect fittings connecting the puller and trigger to the PowerPak manifold.
	(b) Inadequate external pressure.	(b) Adjust external pressure regulator.
	(c) Inadequate air supply.	(c) Check the main air supply has not been interrupted and meets minimum flow requirements (90 psi (0.62MPa), 50 cfm (1.42m <sup>3</sup> /min)).

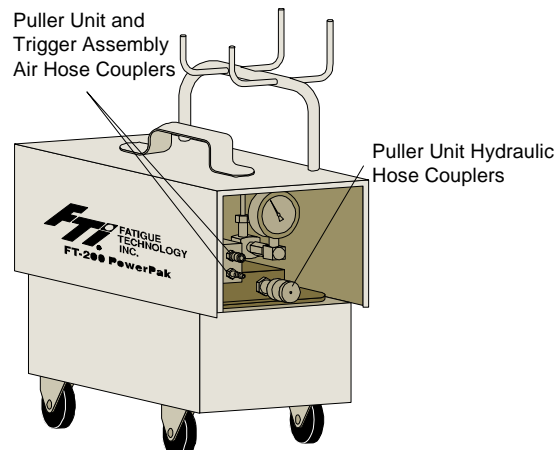

**CAUTION:** Hydraulic oil under extreme pressure may cause serious injuries if not handled carefully. For technical assistance, please contact FTI's technical support staff.

PROBLEM	CAUSE	SOLUTION
<p>2. Puller retracts on first trigger actuation but will not return to start position</p> <p>(b) <b>AND</b> The hydraulic hose is difficult to bend or coil (indicating unrelieved pressure built up in the hose).</p>	<p>(a) The new puller unit requires lubrication through the piston and cylinder.</p> <p>(b) The hydraulic quick coupler line has not been completely tightened at the PowerPak manifold. There should be no space between the PowerPak couple and the hose fitting flange.</p>	<p>(a) Cycle trigger several times to introduce hydraulic fluid into the cylinder.</p> <p>(b) Once hydraulic pressure has been introduced to the hydraulic hose, the pressure must be relieved before the coupler can be sufficiently tightened.</p>

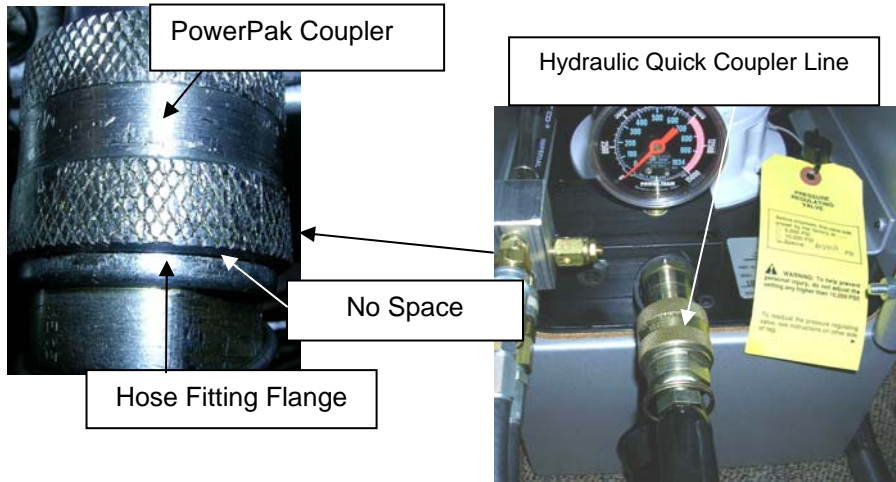

Procedure for relieving hydraulic pressure:

- (1) Disconnect main air supply.
- (2) Disconnect coupler from PowerPak.
- (3) Wrap the fitting with a rag to absorb the squirting oil and slowly turn the coupler off the hydraulic hose to allow hydraulic oil to bleed out.
- (4) Once pressure is relieved, coupler may be tightened and reinstalled onto PowerPak.
- (5) Reattach air lines to get puller to return.
- (6) Check oil level in PowerPak reservoir.

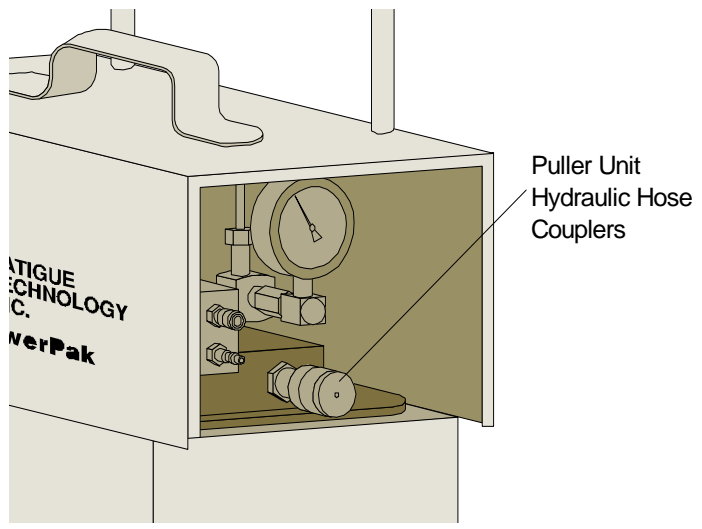

**PROBLEM****CAUSE****SOLUTION**

3. PowerPak will not generate constant pressure (or hiccups).

(a) Trigger response valve requires adjustment.

(a) Adjustment procedure:

- (1) Loosen locknut on trigger response valve.
- (2) Using a screwdriver, open screw counterclockwise until PowerPak will not start when puller trigger is depressed.
- (3) Turn screw clockwise until:
  - PowerPak generates constant pressure when puller trigger is depressed, and
  - PowerPak starts instantly when puller trigger is depressed and stops instantly when released. When the puller trigger is depressed, the PowerPak should be run at the pre-set pressure until the trigger is released.

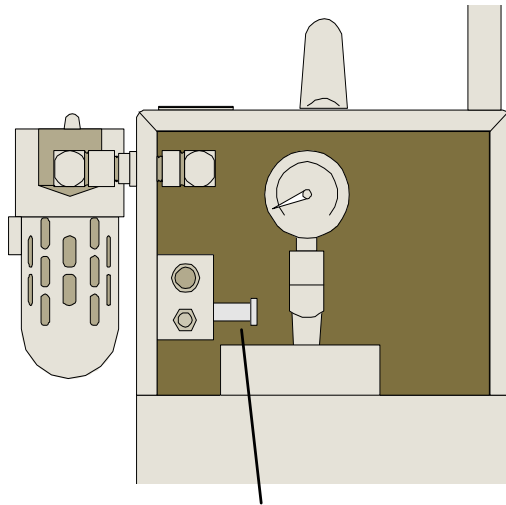

Trigger Response Valve

(4) Hold set screw in position and tighten locknut until snug.

(b) Inadequate air supply.

(b) Check main air flow for 90 psi (0.62MPa), 0cfm(1.42m<sup>3</sup>/min).

**PROBLEM****CAUSE****SOLUTION**

4. PowerPak will not operate or maintain sufficient pressure (10,000 psi (68.95MPa)).

a) Hydraulic pressure requires adjusting.

- (a) Adjust PowerPak pressure valve:
- (1) Squeeze trigger on puller unit to activate PowerPak.
  - (2) If pressure does not reach 10,000 psi (68.95MPa), loosen lock and turn hydraulic pressure control clockwise until pressure reaches 10,000 psi (68.95MPa).
  - (3) Tighten locknut to secure.

(b) Inadequate air supply.

- (b) Increase pressure or flow of available shop air.

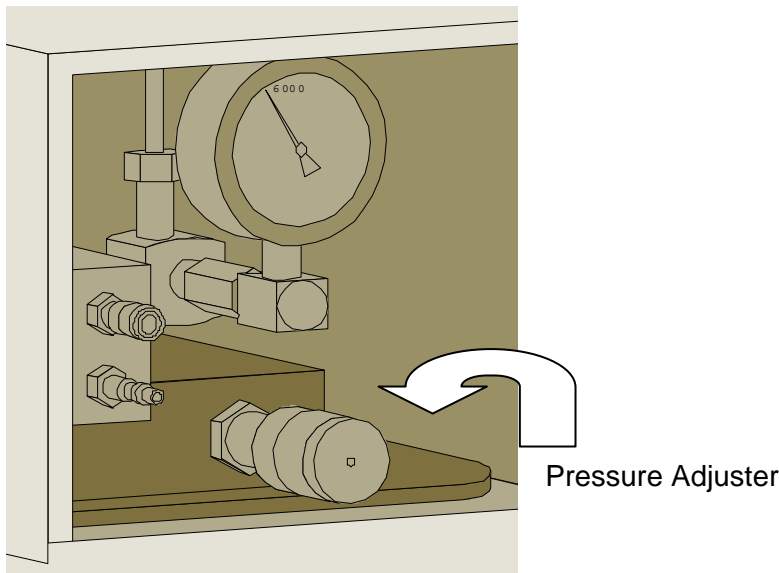

- If the PowerPak will not generate or maintain sufficient pressure, the main air line pressure is too low or the PowerPak hydraulic pressure requires adjustment.
- Air pressure requirements: 1/2-inch (12.7mm) ID air line with 90 to 120 psi (0.62 to 0.83MPa).
- Flow requirements: 40 to 50 cfm (1.13-1.42m<sup>3</sup>/min).

## SECTION 6: ILLUSTRATED PARTS BREAKDOWN

### 6.1 JB-60 PULLER UNIT DIAGRAM

A diagram of the JB-60 Puller Unit is shown in Figure 6.1-1, which corresponds to the parts list in Table 6.2-1.

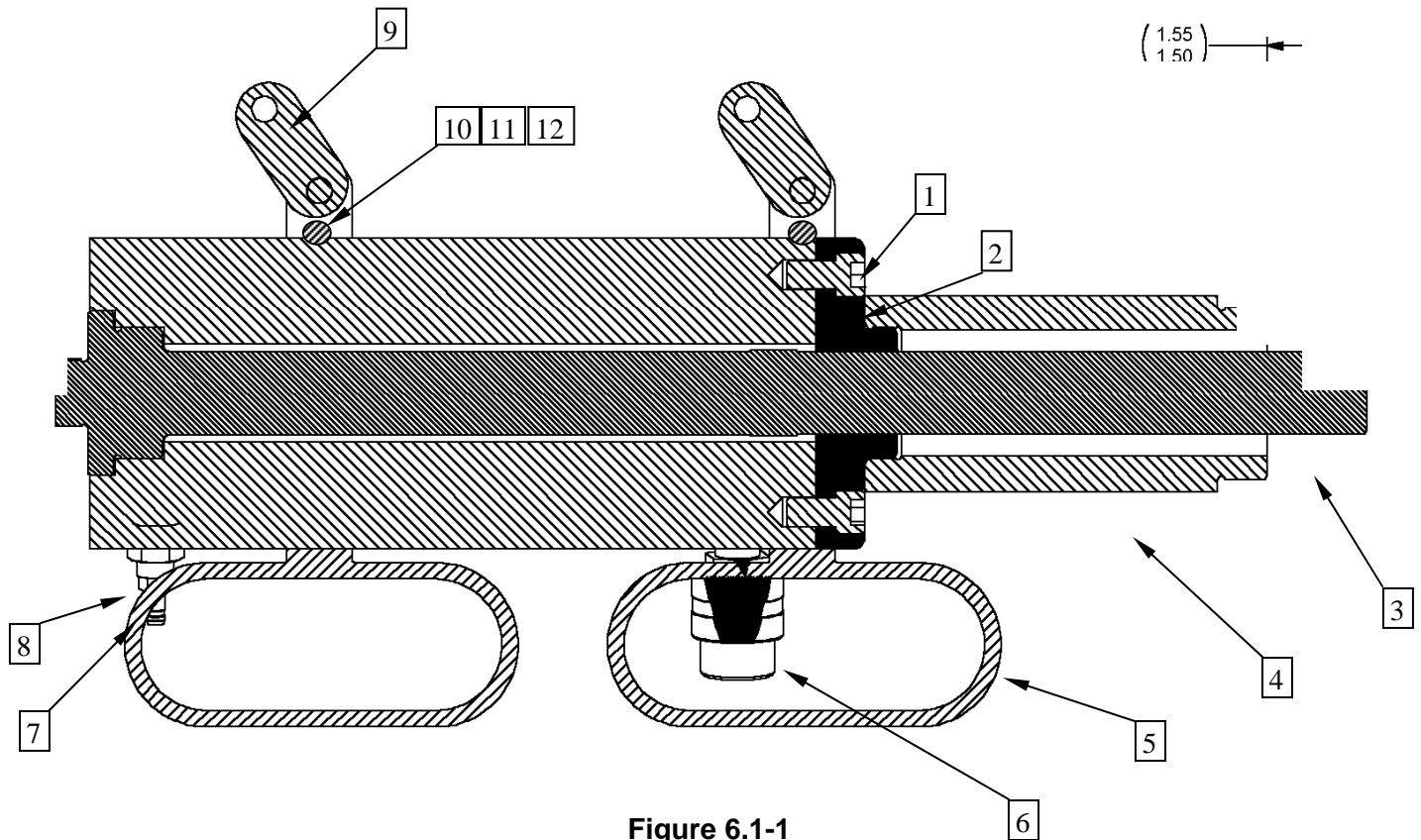

Figure 6.1-1  
JB-60 Diagram

**6.2 JB-60 PULLER UNIT ASSEMBLY PARTS LIST**

The parts list in Table 6.2-1 corresponds to the drawing in Figure 6.1-1 on the previous page.

**Table 6.2-1  
JB-60 Parts List**

<b>Reference Number</b>	<b>Description</b>	<b>Part Number</b>	<b>Notes</b>
1	Faceplate	5555-001	
1	Faceplate (JB-60A)	5555-002	
2	Screw	1042-003	
3	Pull Rod	5559-001	
4	Extension Tube	5500-001	
4	Extension Tube (JB-60A)	5500-002	
5	Lifting Handle	1187-086	
6	Hydraulic Coupler	1047-013	
7	Air Coupler, Male	1047-036	
8	Adapter, Threaded	1047-029	
9	Link, Sling Attachment	3158-001	
10	Bolt	1187-099	
11	Washer	1187-097	
12	Nut	1187-098	
---	Trigger Assembly	2049-007	1
---	Air-Hydraulic Extension Hose Assembly	5628-001	1

Note 1: Not shown in assembly illustration.

### 6.3 JB-60 REMOTE TRIGGER ASSEMBLY; PARTS LIST

#### 6.3.1 JB-60 Remote Trigger Assembly

Fatigue Technology, Inc. has redesigned the remote trigger assemblies to a cartridge trigger assembly. The new design will reduce the occurrence of trigger air leaks, perform more reliably (better pump actuation), and is easier to maintain. As of June 2005, all remote triggers will have the cartridge trigger assembly. The previous trigger design detailed in Section 6.3.2 can be easily replaced with the improved trigger assembly detailed in Section 6.3.1 by purchasing the Cartridge Trigger Assembly Kit (FTI-CT-RK) and the Puller Trigger Rework Tool Kit (FTI-CT-RKT). One FTI-CT-RK kit is required for each remote trigger converted. Only one FTI-CT-RKT is required regardless of the number of remote triggers converted. The FTI-CT-RKT kit also includes detailed instructions on how to perform the modification.

**Table 6.3.1-1  
Parts List for Cartridge Trigger Assembly Kit (FTI-CT-RK)**

Quantity	Line Item	Description	FTI Part Number
1	1	Valve, Cartridge Trigger	1187-622
1	2	Spring, LB Handle	1187-623
1	3	Retainer, LB Handle	1187-624
1	4	Ball, .250 Dia. Stl.	3196-001

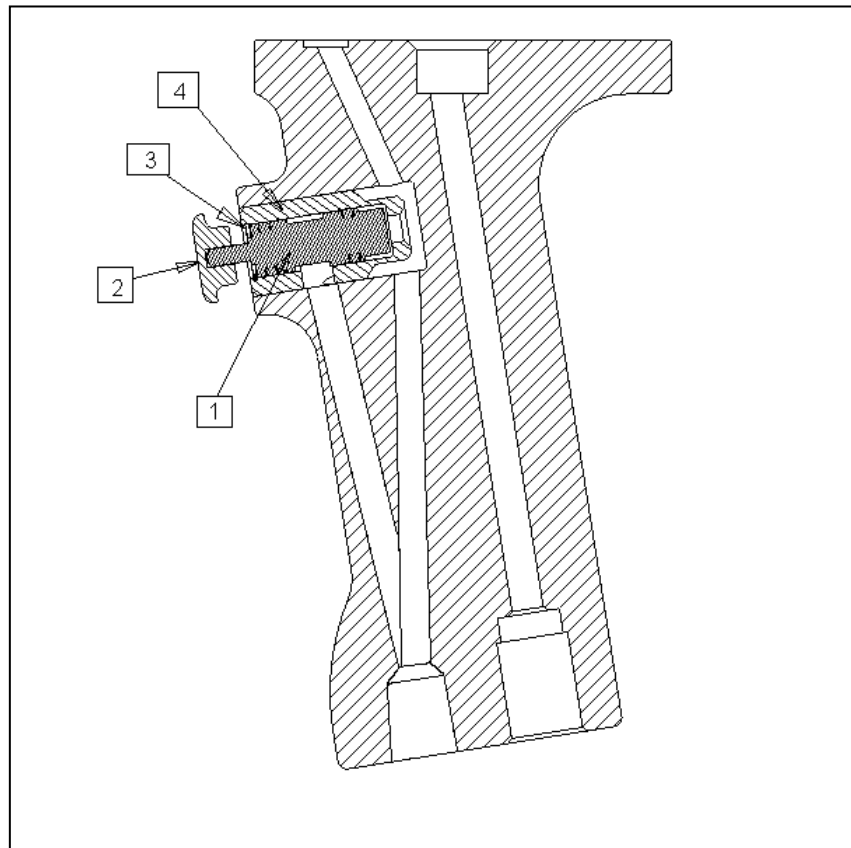

**Figure 6.3.1-1  
Diagram of Remote Trigger Assembly**

#### 6.3.2 JB-60 Previous Remote Trigger Assembly

Remote triggers purchased before June 2005 will have the following trigger assembly. These trigger assemblies can be readily identified by the aluminum pushbutton. (The new trigger assemblies have a brass pushbutton). If you have the previous trigger assembly, you can convert your trigger assembly by purchasing the Cartridge Trigger Assembly Kit (FTI-CT-RK) and the Puller Trigger Rework Kit (FTI-CT-RKT). The parts list below identifies the previous trigger assembly:

**Table 6.3.2-1  
Parts List for Previous Trigger Assembly**

Quantity	Line Item	Description	FTI Part Number
1	1	Trigger, LB Handle	2042-001
1	2	Spring, LB Handle	1005-003
1	3	Retainer, LB Handle	2043-001
1	4	Ball, .250 Dia. Stl.	1045-025
1	5	Pin, 1/8 x 3/4 Std. Spring	1045-026
1	6	Seal, LB Handle	2040-001
1	7	Sleeve, LB Handle	2044-001

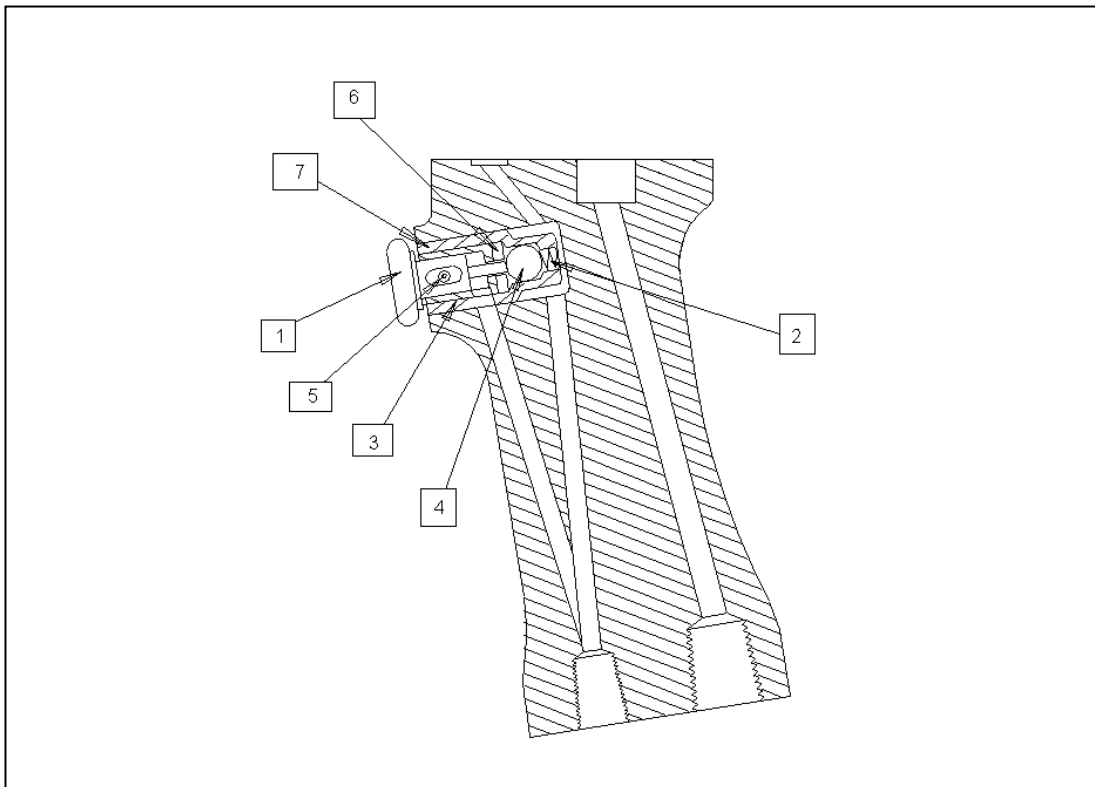

**Figure 6.3.2-1  
Diagram of Previous Trigger Assembly**